

CMC™

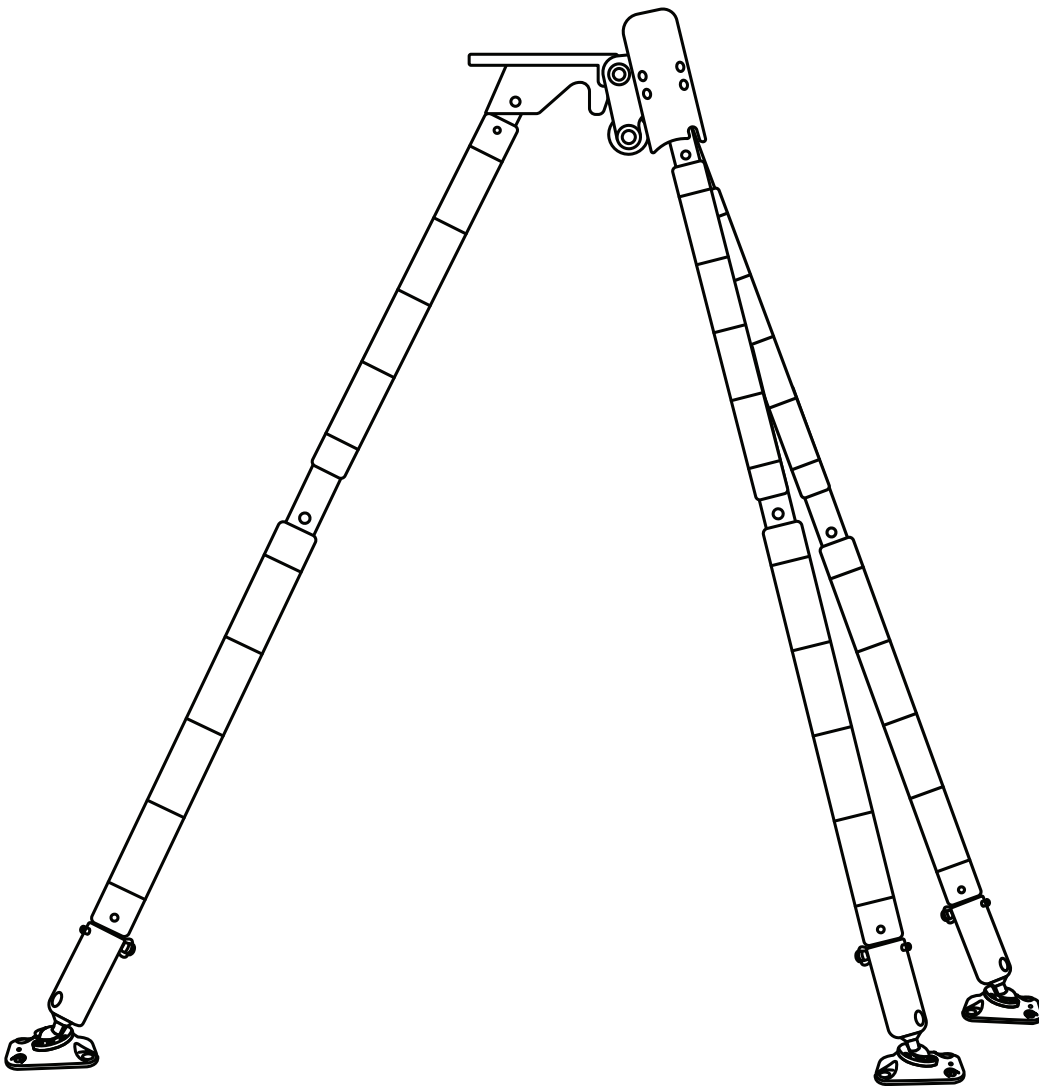
---

# ARIZONA VORTEX KIT

---

USER MANUAL

---



GENERAL USE (G)  
NFPA 1983 (2017 ED)

## TABLE OF CONTENTS

INTRODUCTION	3
APPLICATION	3
DESIGN PRINCIPLES	3
CARE & USE	3
CERTIFIED CONFIGURATIONS	4
GENERAL WARNINGS	5
VORTEX SPECIFIC WARNINGS	5
VORTEX COMPONENTS	6
VORTEX HARDWARE	7
VORTEX ASSEMBLY	8
BASIC CONFIGURATIONS	14
MULTIPOD SET-UP AND USE	15
EQUAL-LEG TRIPOD	23
EASEL-LEG TRIPOD	24
A-FRAME BIPOD	27
SIDEWAYS A-FRAME	28
GIN POLE MONOPOD	29
INSPECTIONS	30
WARRANTY & SERVICE	31

## INTRODUCTION

Congratulations on your purchase of the Arizona Vortex Kit (Vortex). The Vortex is the most versatile, state of the art and functional multipod available to the rope rigging industries. With proper study and practical training, you can construct the Vortex to accomplish your rigging needs in any number of environments from industry to wilderness.

**SPECIALIZED TRAINING AND EXPERIENCE IN TECHNICAL RIGGING IS ABSOLUTELY ESSENTIAL FOR SAFE USE.**

**THIS MANUAL IS NOT A SUBSTITUTE FOR TRAINING. THIS MANUAL IS A REFERENCE FOR ASSEMBLY AND BASIC OPERATION OF THE VORTEX.**

## APPLICATION

The Vortex is ideal for a wide range of applications, from access and egress to confined spaces, to the negotiation of complex edges in wilderness environments. The Vortex is the multipod of choice for professionals within rescue, industrial rope access, construction, military and entertainment rigging.

## DESIGN PRINCIPLES

The Vortex multipod is more than a typical tripod, in part due to the enhanced flexibility of the two piece head set. The A-Frame Head has been designed to give the most optimal angle between the legs, while the Gin Pole Head can hinge to allow precise positioning of the third leg. The multipod can be assembled into a three-leg frame using both heads or they can be used individually to create an A-Frame or a Gin Pole.

The legs of the Vortex are made up of two components. The Inner Legs (shiny, anodized finish) are one constant diameter with adjustment pin holes at 150 mm (5.9") increments along the leg. The Inner Leg is sized to connect to the heads, the feet and the Outer Legs.

The Outer Legs (matte gray) have a coupler on one end that enables multiple Outer Legs to join together. The coupler is also sized to connect to the heads and the feet.

The head units are designed on a rigging plate principle allowing attachment of multiple connectors as well as direct tie-in of rope, cord, and webbing. Ball-lock pins are also included for attachment of the head sheave and other compatible rigging components.

## CARE & USE

**Service Life:** The maximum service life of the Vortex metal products is not defined; however, the lifespan may be reduced by frequency of use, adverse loading, incompatible environment, incorrect use or inappropriate storage and handling.

**Inspection frequency:** The Vortex must undergo a detailed periodic inspection by a competent person at least every 12 months. The frequency of inspection may be more often depending on the nature of use and the environment in which it is used. If you have any doubts or questions about the safety or suitability of the Vortex, or any part thereof, remove the product from service and contact CMC.

In addition to the detailed periodic inspection, the Vortex must be inspected before and after each use. Ideally, users of the Vortex will be trained to perform this function. The inspection should include a tactile, visual and functional check of all Vortex components. Refer to the inspection criteria in this User Manual for further information.

**Record keeping:** A record of inspections should be kept and made available in accordance with applicable laws, codes of practice and policies. A sample inspection record is provided at the end of this User Manual.

**Preventive Maintenance / Storage:** To ensure maximum longevity of the Vortex, prevent contact with salt water, chemicals and other potentially harmful substances. Avoid exposing the Vortex to harsh environments when practical.

Wash all components with fresh water after use to remove dirt, grime, salt and other chemicals or contaminants. Dry, or allow to dry away from direct heat. Store the Vortex in a clean dry place away from extremes of temperature and avoid chemical exposure. Small burs may be lightly smoothed with a fine abrasive cloth.

**CMC Rescue, Inc.**  
6740 Cortona Drive  
Goleta, CA 93117 USA  
info@cmcpro.com  
USA

International  
Ph 800-513-7455  
Fx 800-235-8951

Domestic U.S.  
Ph 805-562-9120  
Fx 805-562-9870



Arizona Vortex Kit  
CMC Item # 727300  
Patented  
Made in the USA using foreign  
and domestic materials



**WARNING:** This product can expose you to chemicals including nickel acetate, which is known to the State of California to cause cancer. For information go to [WWW.P65Warnings.ca.gov](http://WWW.P65Warnings.ca.gov)

## VORTEX NFPA CERTIFIED CONFIGURATIONS



5F04

MEETS THE PORTABLE ANCHOR REQUIREMENTS OF NFPA 1983, STANDARD ON LIFE SAFETY ROPE AND EQUIPMENT FOR EMERGENCY SERVICES, 2017 EDITION.

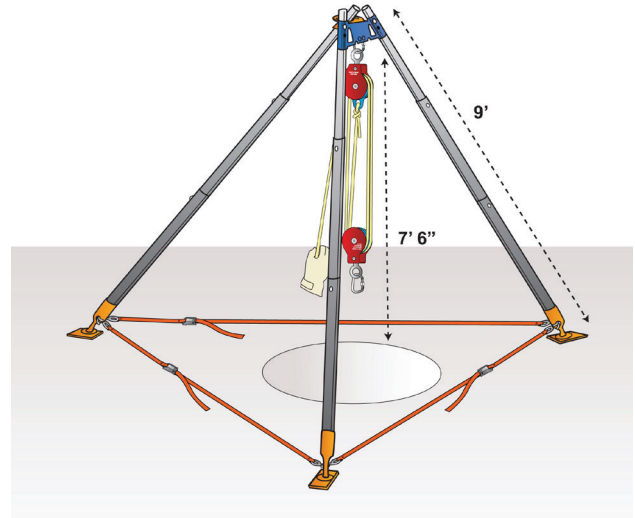
EMERGENCY SERVICES PORTABLE ANCHOR IN ACCORDANCE WITH NFPA 1983, 2017 EDITION.

MINIMUM BREAKING STRENGTH AND RATING ARE DETERMINED AT THE CONFIGURATION OF LOWEST STRENGTH PER MANUFACTURER'S INSTRUCTIONS.

RATED G (GENERAL USE), MBS 36 kN FOR THE FOLLOWING CONFIGURATIONS:

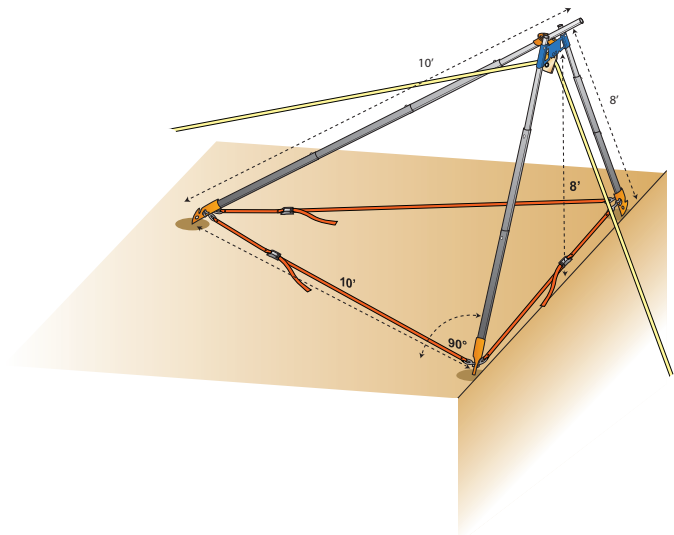
### CONFIGURATION 1 Tripod (all legs equal length)

1. 2 outer legs coupled to 1 inner leg at maximum length (9 ft / 2.7 m)
2. Head unit connected to the inner leg via upper head pin hole and last inner leg pin hole
3. Use either Raptor or Flat Feet
4. Legs at equal distance apart
5. Feet are required to be individually hobbled or anchored



### CONFIGURATION 2 Easel A-Frame

1. A-FRAME SECTION 2 outer legs coupled to 1 inner leg at maximum length (8 ft / 2.4 m)
2. EASEL LEG SECTION 3 outer legs coupled to 1 inner leg at maximum length (10 ft / 3.0 m)
3. A-frame head unit connected to the inner leg via upper head pin hole and third to last outer leg pin hole
4. Easel head unit connected to the inner easel leg via third-to-last leg pin hole
5. A-frame section must be at 90 degrees relative to the surface
6. Use either Raptor or Flat Feet
7. Easel leg to A-frame leg distance 10 ft (3 m)
8. Feet are required to be individually hobbled or anchored








## GENERAL WARNINGS

- These instructions DO NOT inform you of every possible hazard and every conceivable risk relating to the use of this equipment.
- The environment where this equipment can be used may be inherently dangerous. Activities performed within these environments carry a high risk of injury and death. Although proper training and experience may reduce this risk, ultimately the risk cannot be eliminated.
- Do not use this equipment unless you fully understand and assume all risks and responsibilities for all damage / injury / death that may result from use of this equipment or the activities undertaken with it.
- The Vortex is intended for use by medically fit, specifically trained and experienced users.
- All users of this equipment must obtain and thoroughly understand the user instructions and refer to them before each use.
- Any time a person is suspended by a rope based system, a secondary system should be in place in case of a component failure. You must always have a backup. Never trust your life to a single tool or component.
- The user must have a rescue plan and the means to implement it. Inert suspension in a harness can quickly result in death!
- Do not use around electrical hazards, moving machinery, or near sharp edges or abrasive surfaces.
- Do not exceed the limits of the equipment.
- Verify compatibility with other components of your system. Incompatible connections can cause detachment, breakage, etc.
- CMC is not responsible for any direct, indirect or accidental consequences or damage resulting from the use or misuse of this product.
- The user must stay up to date! Regularly access the CMC website and read the latest advice and user instructions.
- Please note that some diagrams in this manual have omitted guy lines and hobble straps for clarity. Guy lines and other methods for properly securing and supporting the Vortex are essential for safe operation and use.

## VORTEX SPECIFIC WARNINGS

- The Vortex is not like a standard tripod. The user must have a greater level of knowledge and understanding to secure and stabilize the Vortex.
- The Vortex head and feet must be secured to resist all movement.
- The Vortex should, whenever possible, be constructed away from the edge. Prior to moving it into position the supplied Tether Cord should be attached to the head of the assembly and configured as a belay while the Vortex is being moved and secured into position.
- The head hinge joint and the Flat Foot ball joint loaded to their rotational limits can create a leverage affect that may damage components.
- The ball joints of the Flat Feet are not designed to withstand tensile forces. The leg, and/or the head, must be secured to ensure these are not subjected to tensile forces.
- All legs must be fully inserted into, or extend beyond the A-Frame head.
- The edges of the A-Frame Pulley Wheel are not fully enclosed. To avoid damaging the rope or adding unwanted friction to the system, it is essential that the rope running into and out of the Pulley Wheel is correctly aligned.
- Do not couple more than four (4) leg sections (three Outer plus one Inner Leg) together on any one leg.
- Check the ball-lock pins after insertion to ensure they are completely inserted and the locking balls are fully extended and locked.

## DIAGRAM LEGEND

SYMBOL	MEANING
	Haul line
	Mass of payload
	Straps preventing feet from spreading apart
	Line preventing the Vortex from toppling
	Total force acting on frame

# ARIZONA VORTEX KIT

## SPECIFICATIONS:

- HORIZONTAL CLEARANCE: 8 ft 9 in (2.6 m) at foot level in 9 ft height configuration
- MAX HEIGHT WITH ADDITIONAL LEGS: 12 ft (3.7 m)
- SYSTEM WEIGHT: 72 lb (33 kg) with both sets of feet
- PIN STRENGTH: 18,000 lbf (80 kN) for the 3/8-inch leg pins  
32,000 lbf (142 kN) for the 1/2-inch head pins

## COMPONENTS:

- 2-Piece Head Set
- Head Set Pulley Wheel
- Head Pins (4)
- Inner Legs (3)
- Outer Legs (7)
- Leg/Foot Pins (17)
- Flat Feet (3)
- Raptor Feet (3)
- Orange Pin Flags (21)
- Adjustable Hobble Straps (3)
- 8mm Tether Cord (40ft)
- User Manual

## BAG SET:

- RigTech Pack™
- Leg Bags (2)
- Foot Set Sleeves (2)
- Pin Storage Bag



# VORTEX HARDWARE

Most of the Vortex hardware components are machined from solid aluminum and incorporate design features that reduce weight and increase strength.

**x7**

**A OUTER LEG**

Attaches to feet. Can be reversed to fit into A-Frame & Gin Pole Heads.

**x3**

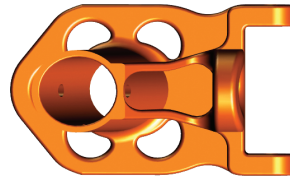
**B INNER LEG**

Attaches to A-Frame, Gin Pole Head and feet. Fits within Outer Leg to adjust height or join two Outer Legs.

**x1**

**C GIN POLE HEAD**

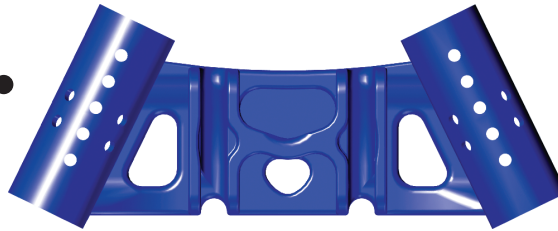
Connects to the A-Frame Head to construct tripod & variants.



**x1**

**D A-FRAME HEAD**

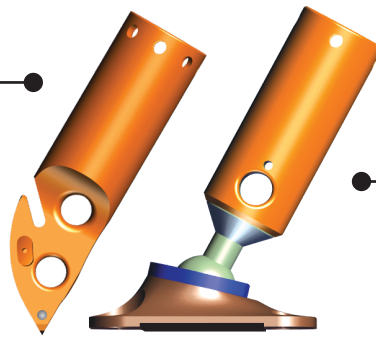
Attaches to Legs and Gin Pole Head to create tripod and other custom configurations.



**x3**

**E RAPTOR FEET**

Uses replaceable carbide tip for optimal grip on appropriate surfaces. Rotates to adjust orientation.



**x3**

**F FLAT FEET**

Features rubber sole for optimal grip on flat surfaces. Ball joint easily adjusts to necessary angle.



**x1**

**G PULLEY WHEEL**

1.5" Pulley Wheel attaches to A-Frame Head using Head Pin. Uses high-efficiency bearing.



**x17**

**H LEG & FOOT PINS**  
(Ball-lock Pin 3/8")

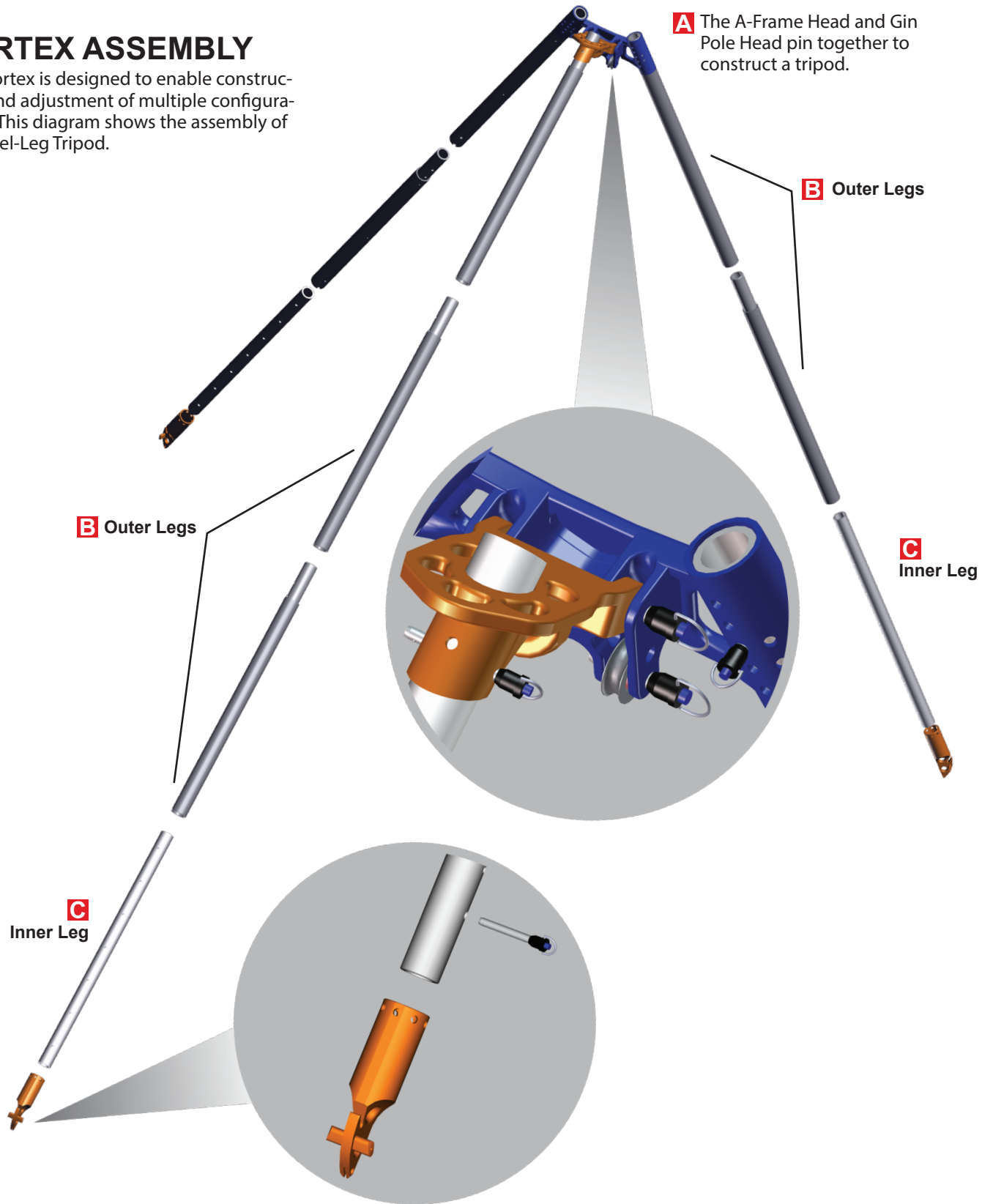
**x4**

**I HEAD PINS**  
(Ball-lock Pin 1/2")



# VORTEX ASSEMBLY

The Vortex is designed to enable construction and adjustment of multiple configurations. This diagram shows the assembly of an Easel-Leg Tripod.

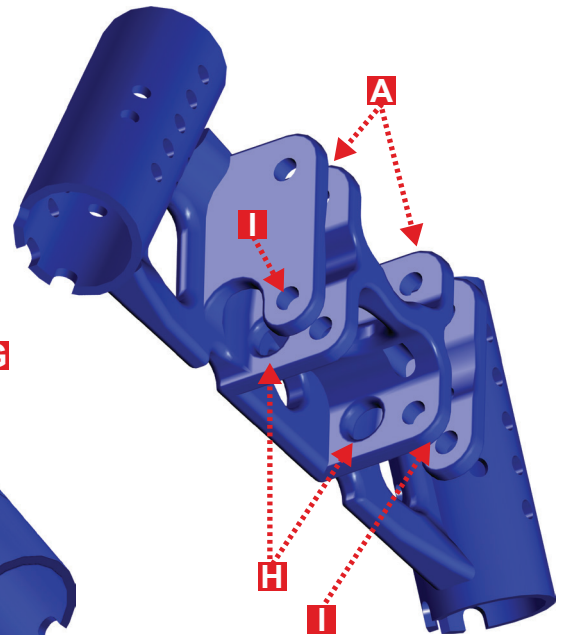
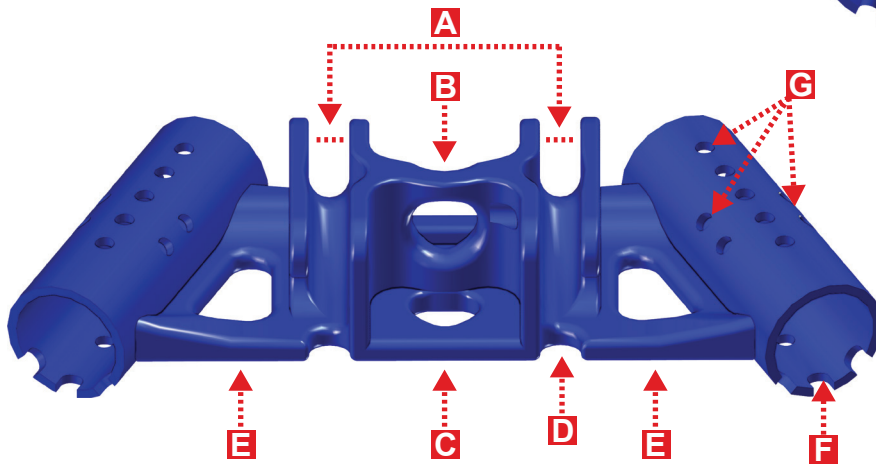




## A-FRAME HEAD

### DETAIL VIEW

The A-Frame Head can be used individually to construct bipod configurations such as a Classic A-Frame or a Sideways A-Frame. The A-Frame Head has been designed to give the optimal angle between the legs. The Gin Pole Head (orange) can be connected to the A-Frame Head with two pins, allowing it to hinge or swing. This enables the third leg to be positioned for specific applications.



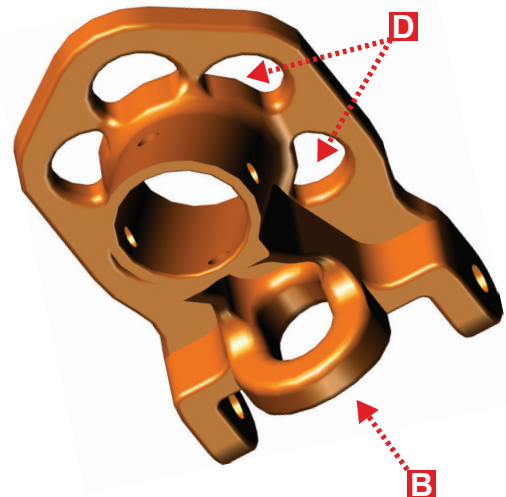
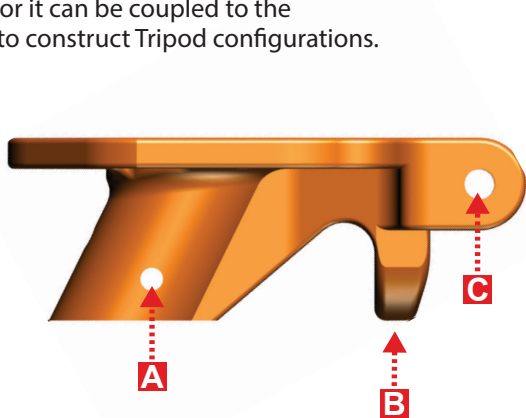
- A. 1/2" connection points for Gin Pole Head
- B. Horizontal center connection point
- C. Vertical center connection point
- D. Recessed path for rope passage
- E. Left and right anchor points

- F. Multiple Outer Leg pin alignment slots
- G. Multiple leg pin adjustment holes
- H. Left and right side facing rigging points
- I. Left and right 1/2" pin connection points

## GIN POLE HEAD

### DETAIL VIEW

The Gin Pole Head can be used for Monopod configurations or it can be coupled to the A-Frame Head to construct Tripod configurations.



- A. 3/8" Leg Pin attachment hole
- B. Center Gin Pole yoke
- C. 1/2" Head A-Frame connection point
- D. Radial anchor points

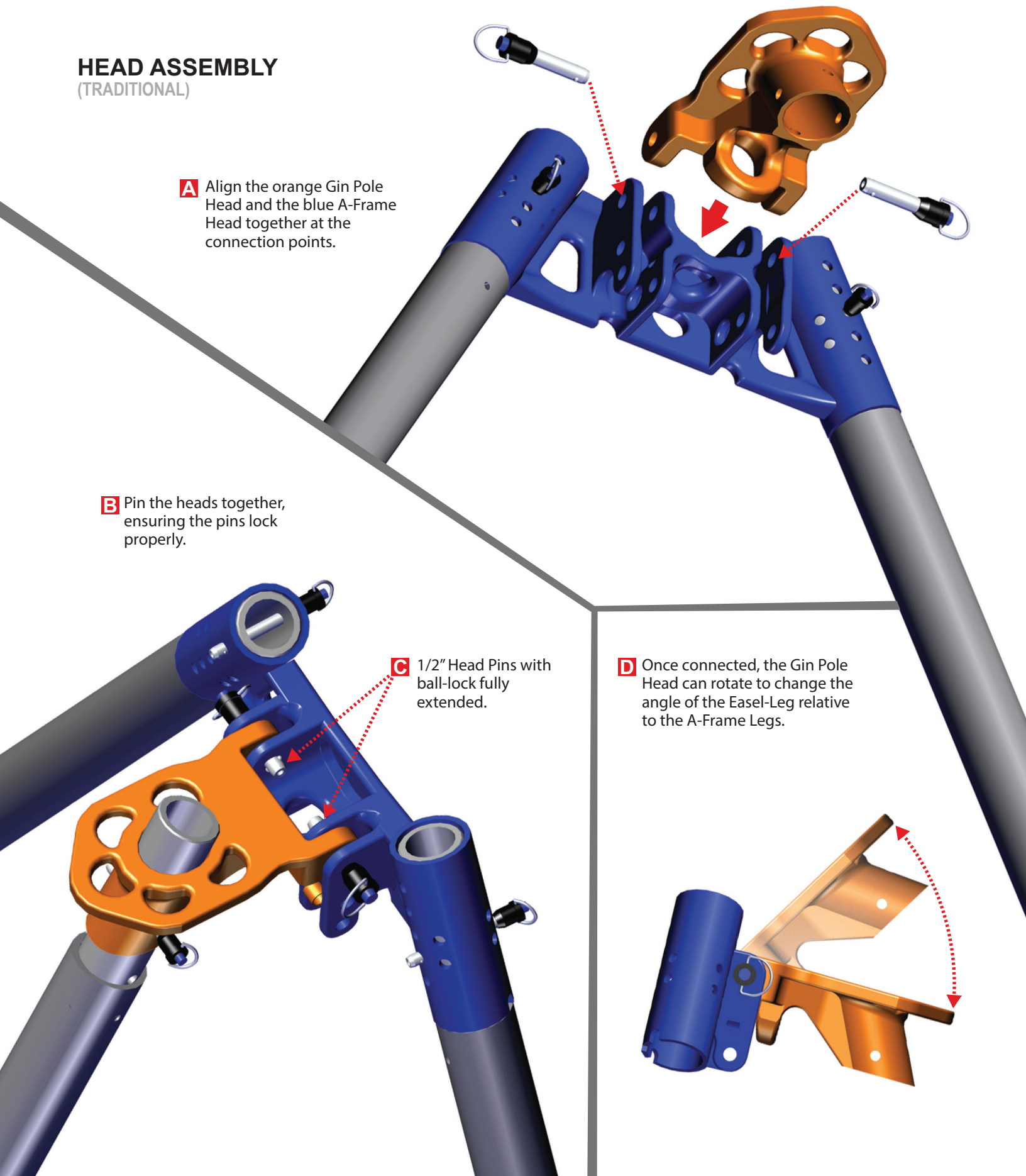
## HEAD ASSEMBLY (TRADITIONAL)

**A** Align the orange Gin Pole Head and the blue A-Frame Head together at the connection points.

**B** Pin the heads together, ensuring the pins lock properly.

**C** 1/2" Head Pins with ball-lock fully extended.

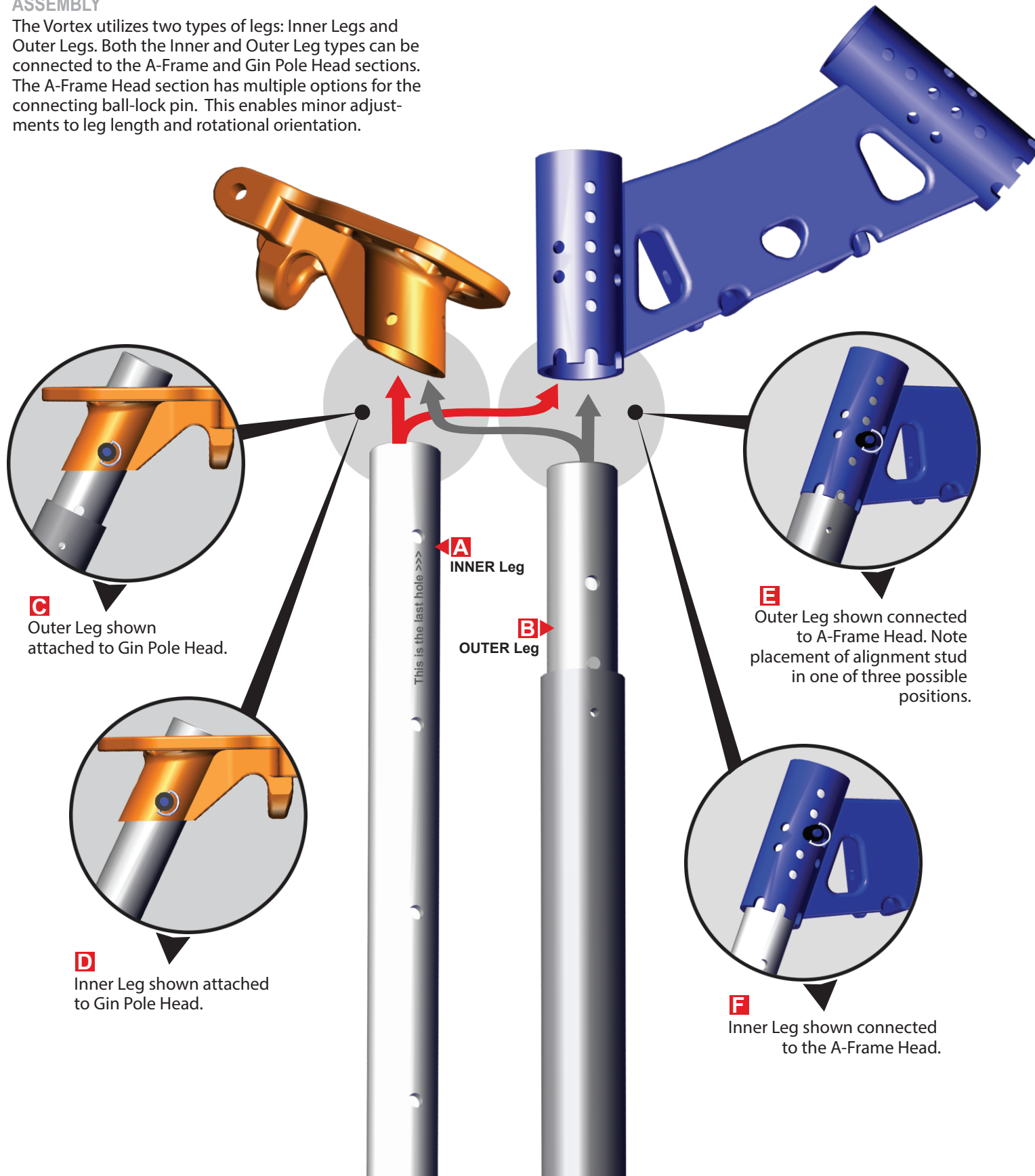
**D** Once connected, the Gin Pole Head can rotate to change the angle of the Easel-Leg relative to the A-Frame Legs.



# LEGS TO HEADS

## ASSEMBLY

The Vortex utilizes two types of legs: Inner Legs and Outer Legs. Both the Inner and Outer Leg types can be connected to the A-Frame and Gin Pole Head sections. The A-Frame Head section has multiple options for the connecting ball-lock pin. This enables minor adjustments to leg length and rotational orientation.



**C** Outer Leg shown attached to Gin Pole Head.

**D** Inner Leg shown attached to Gin Pole Head.

**A** INNER Leg

**B** OUTER Leg

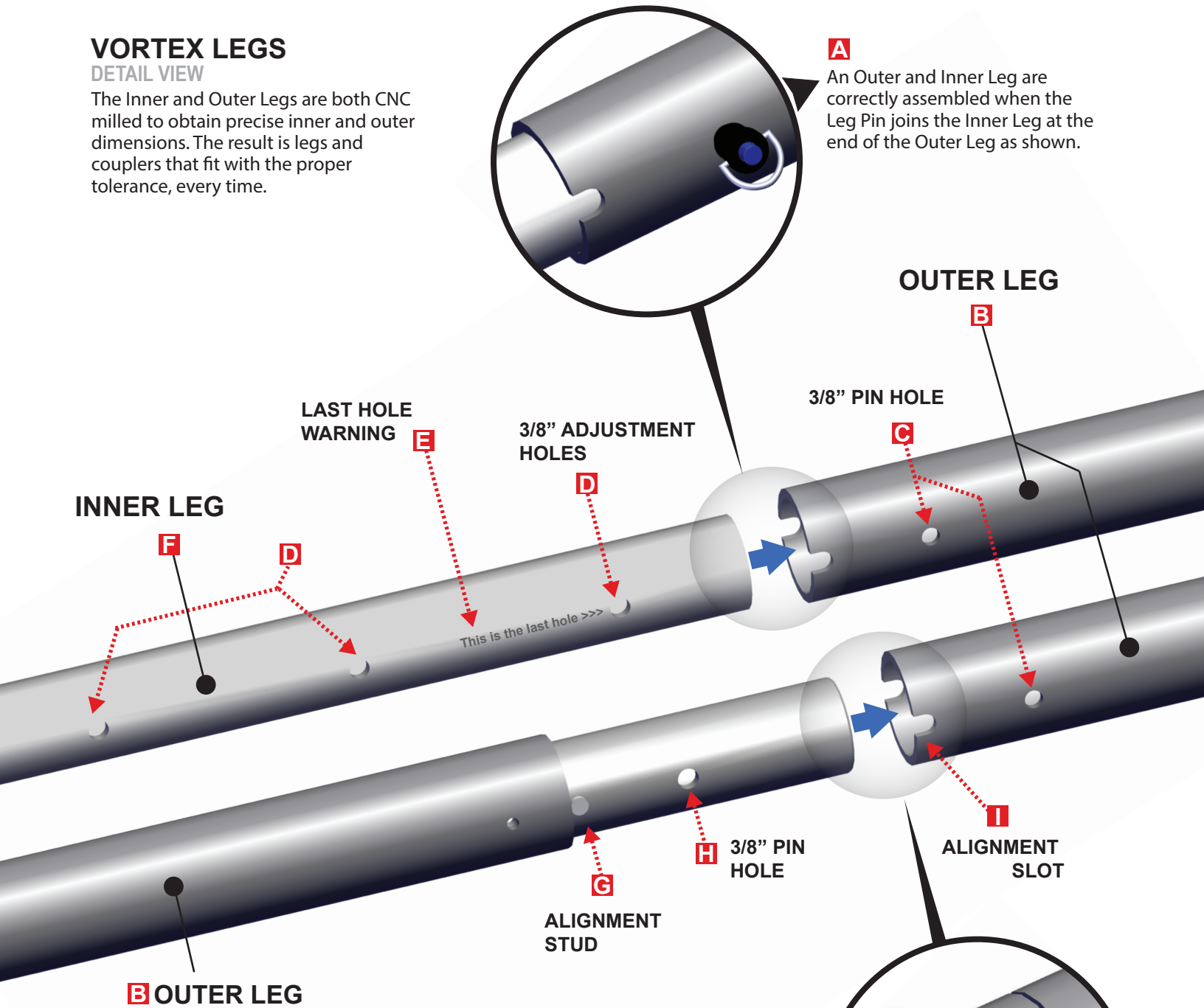
**E** Outer Leg shown connected to A-Frame Head. Note placement of alignment stud in one of three possible positions.

**F** Inner Leg shown connected to the A-Frame Head.

## VORTEX LEGS

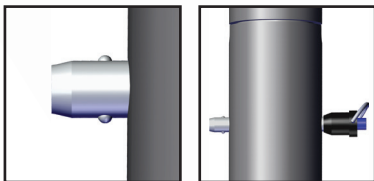
### DETAIL VIEW

The Inner and Outer Legs are both CNC milled to obtain precise inner and outer dimensions. The result is legs and couplers that fit with the proper tolerance, every time.



**A** An Outer and Inner Leg are correctly assembled when the Leg Pin joins the Inner Leg at the end of the Outer Leg as shown.

**J** Correct Pin Placement:  
Pin balls should extend outside the wall of the leg, securing pin in place.



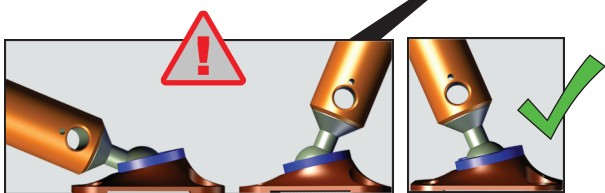
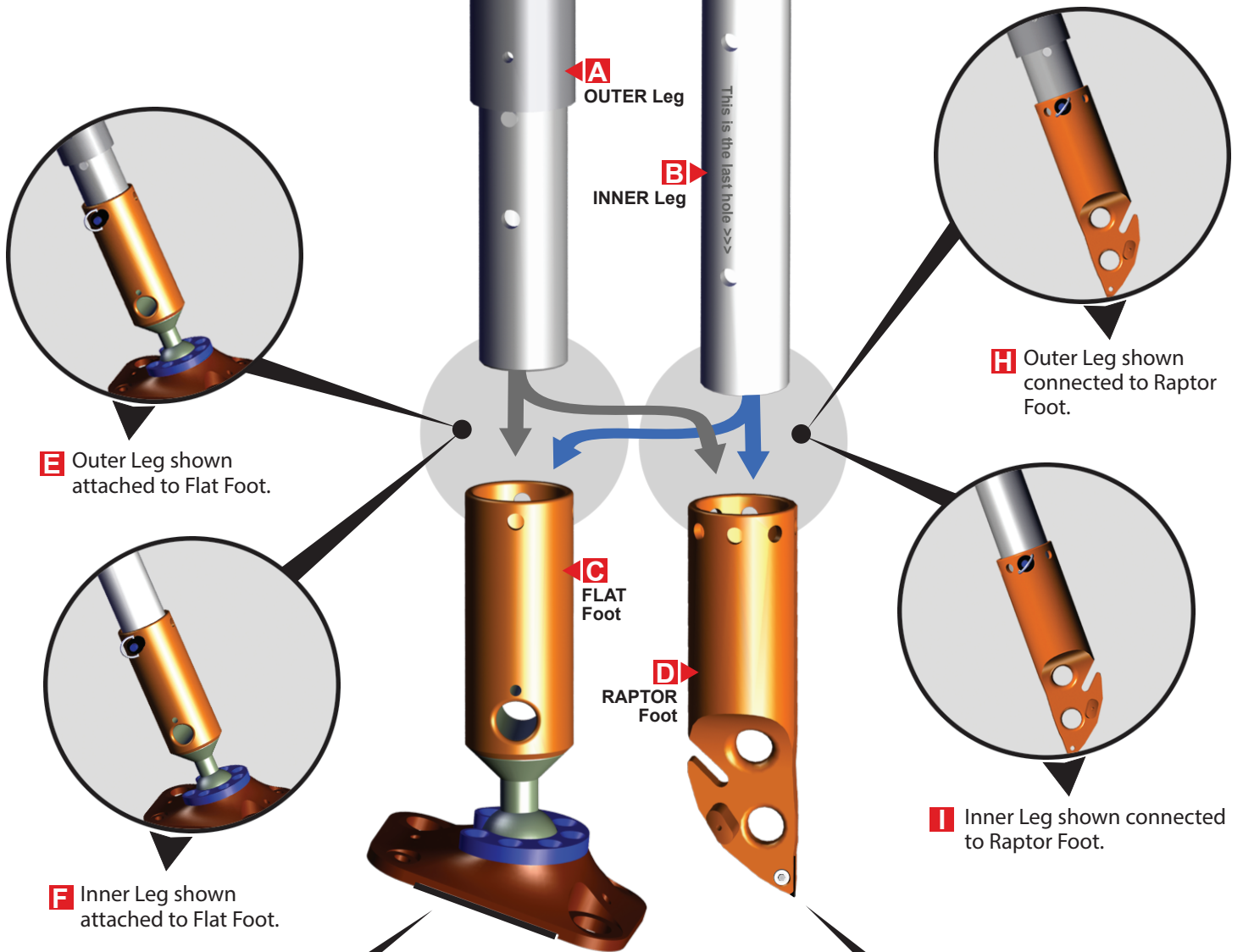
**K** Two Outer Legs are correctly connected when the alignment stud fits properly into the slot on the other Outer Leg with the ball-lock pin inserted as shown.



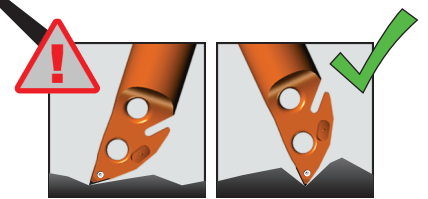
## LEGS TO FEET

### ASSEMBLY

Both the Raptor Foot and Flat Foot will connect with the Inner Leg and Outer Leg.



**G Correct Position of FLAT Foot**  
The ball joint of the Flat Foot should not be set at its limit of articulation without ensuring that further movement will not occur.



**J Correct Position of RAPTOR Foot**  
The Raptor Foot should be positioned to ensure greatest grip onto the surface.

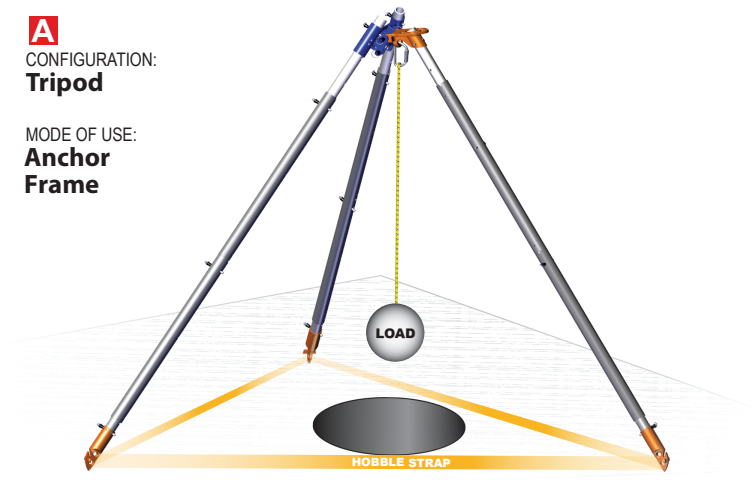
# BASIC CONFIGURATIONS

## OVERVIEW

NOTE: GUY LINES OMITTED FOR CLARITY.

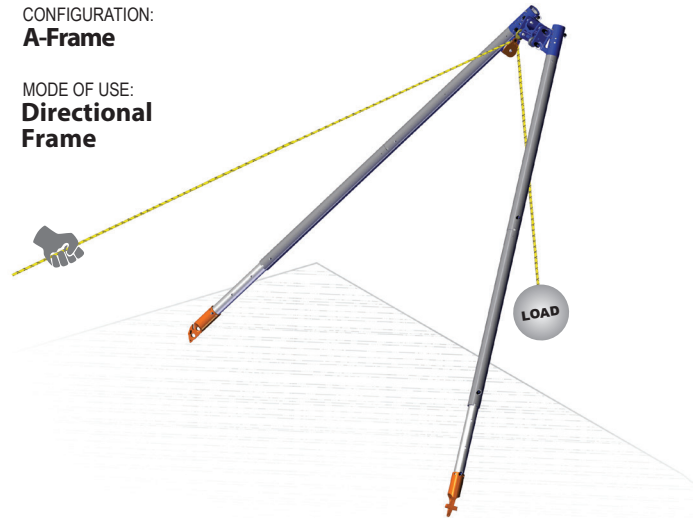
**A**  
CONFIGURATION:  
**Tripod**

MODE OF USE:  
**Anchor  
Frame**



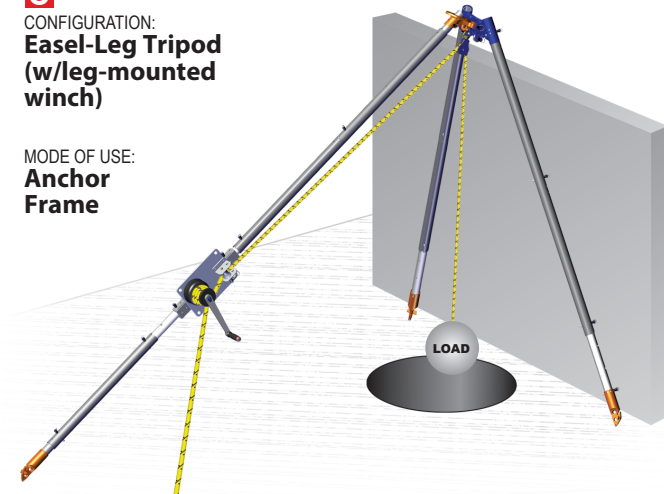
**B**  
CONFIGURATION:  
**A-Frame**

MODE OF USE:  
**Directional  
Frame**



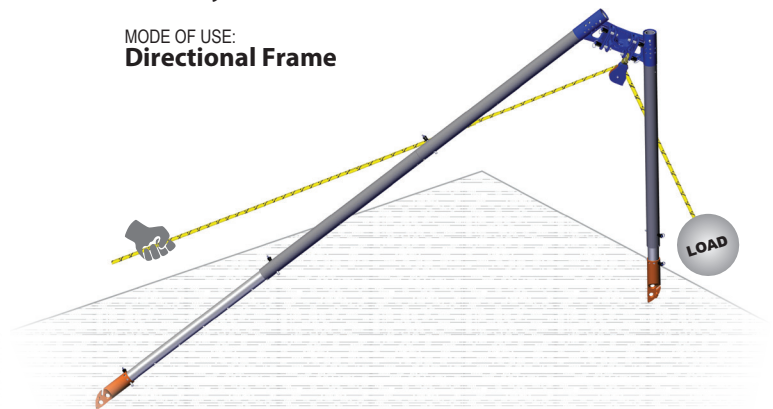
**C**  
CONFIGURATION:  
**Easel-Leg Tripod  
(w/leg-mounted  
winch)**

MODE OF USE:  
**Anchor  
Frame**



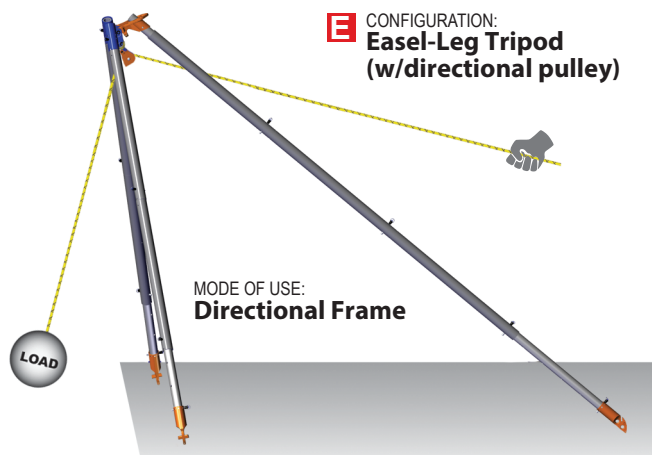
**D**  
CONFIGURATION:  
**Sideways A-Frame**

MODE OF USE:  
**Directional  
Frame**



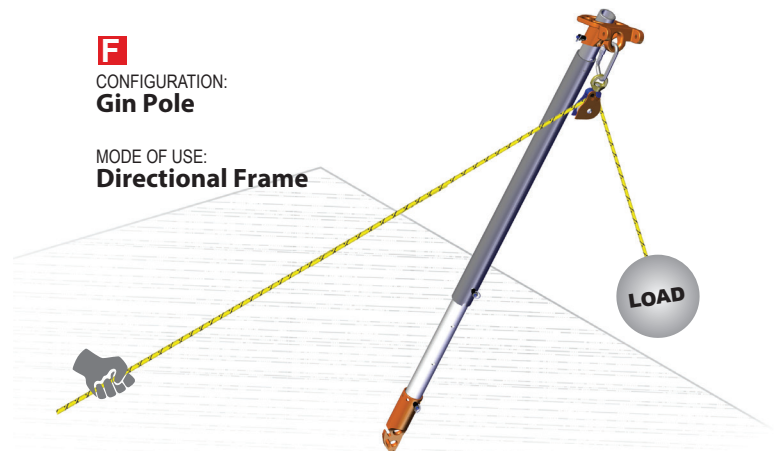
**E** CONFIGURATION:  
**Easel-Leg Tripod  
(w/directional pulley)**

MODE OF USE:  
**Directional  
Frame**



**F**  
CONFIGURATION:  
**Gin Pole**

MODE OF USE:  
**Directional  
Frame**



## Multipod Set-Up and Use

**IT IS VITAL THAT THE USER BE ABLE TO DETERMINE THE DIRECTION AND THE MAGNITUDE OF THE FORCES ACTING ON THE FRAME. THE FRAME NEEDS TO BE ASSEMBLED, HOBbled, GUYED AND OPERATED TO RESIST ALL FORCES WITHOUT ANY MOVEMENT OF THE FRAME AND ASSOCIATED EQUIPMENT.**

The steps below are a guide to successful Vortex setup and operation. Never leave an unsecured Vortex unattended.

As in any rigging situation, one person should be in charge of the set up and communication should be deliberate and precise.

### RECOMMENDATIONS FOR SETUP

CMC highly recommends training for the assembly portion of the Vortex in a safe environment where all participants can concentrate on the relevant tasks.

- Whenever possible, setup the Vortex away from the fall hazard zone, then walk it to the edge. Support each leg section until the unit is secured to prevent toppling during set up.
- Take measures to prevent the Vortex from toppling over the edge during setup and rigging. Attach the supplied Tether Cord to the head of the assembly and configure it as a belay while the Vortex is being moved and secured into position.

#### STEP 1 Identify the Mode of Use.

##### Anchor Frame

Where the rope supporting the load is terminated onto the Vortex.

##### OR

##### Directional Frame

Where the rope supporting the load is not terminated onto the Vortex, but rather is redirected through a pulley which is supported by the Vortex.

#### STEP 2 Identify the Applied Force (Resultant).

Determine the magnitude and direction of the applied force:

- Planned movements of the load.
- Foreseeable unplanned movements of the load.

#### STEP 3 Identify the Tendency of Movement.

The head and the feet of the frame will tend to move if not restrained.

#### STEP 4a Determine the Foot Securing Requirements.

The feet are secured to prevent any movement of the feet and the frame.

#### STEP 4b Determine the Head Securing Requirements.

The head of the frame is typically secured using guys. The guys give strength and rigidity to the frame.

#### STEP 5 Ensure Guy Angles are within limits.

Ensure guy / guy plane angles are:

- Not less than 30°.
- Not less than the applied force angle.

#### STEP 6 Test load the rigging to ensure frame stability and security.

Ensure the rigging is tested by applying load to the system in a safe situation. This test should be performed prior to supporting personnel in a potentially hazardous area.

NOTE: GUY LINES OMITTED AND HOBBLE STRAPS FOR CLARITY.

## Step 1: Mode of Use

The Vortex is used to support ropes, pulleys and other rope rigging equipment. The three most common functions are to:

- A. Support ropes directly from the head of the frame (fig. 1a).
- B. Support ropes from a leg-mounted winch, through a directional pulley on the head of the frame (fig. 1b).
- C. Support a directional pulley or pulley system on the head of the frame (fig. 1c).

For correct rigging, the user must know both the *direction* and *magnitude* of the force acting on the frame. For this purpose we have designated two primary Modes of Use:

**Anchor Frame** – The rope supporting the load is terminated (anchored) to the Vortex (figures 1a and 1b).

**Directional Frame** – The rope is not terminated to the Vortex but rather is redirected through a pulley which is supported by the Vortex (fig. 1c).

## Step 2: Identify the Applied Force

Knowing the Mode of Use will assist the user in determining the applied force (force acting on the frame).

### Anchor frame

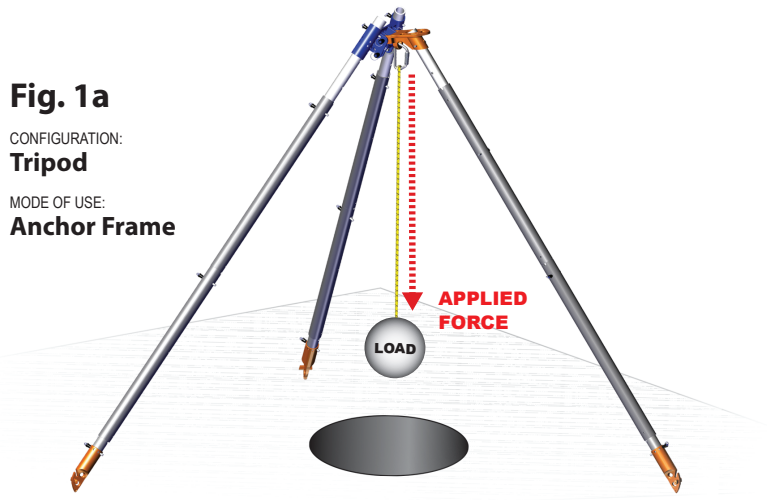
- The magnitude of the applied force will be equivalent to the mass of the load.
- The direction of the applied force will be along the load line towards the load from the last point of contact the load line has with the frame.

### Directional frame

- The magnitude of the applied force will be equivalent to the mass of the load multiplied by the load factor of the directional pulley / pulley system (resultant force).
- The direction of the applied force will be the bisect of the lines running into and out of the directional pulley / pulley system (resultant force).

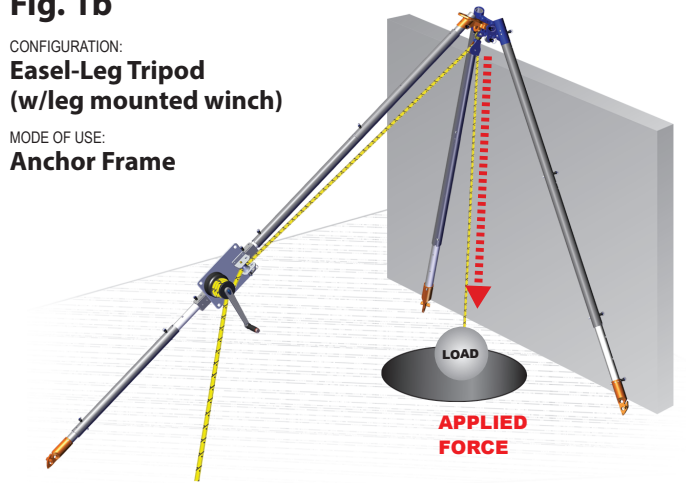
**Fig. 1a**

CONFIGURATION:  
**Tripod**  
MODE OF USE:  
**Anchor Frame**



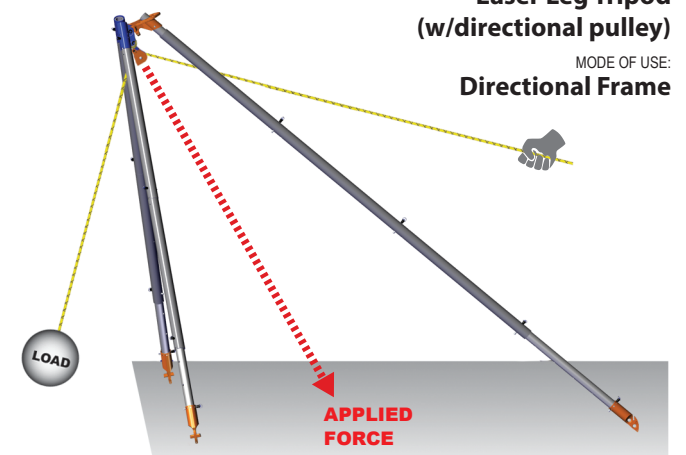
**Fig. 1b**

CONFIGURATION:  
**Easel-Leg Tripod (w/leg mounted winch)**  
MODE OF USE:  
**Anchor Frame**



**Fig. 1c**

CONFIGURATION:  
**Easel-Leg Tripod (w/directional pulley)**  
MODE OF USE:  
**Directional Frame**





### Step 3: Tendency of Movement

To identify the Tendency of Movement of the feet and the head of the frame, consider:

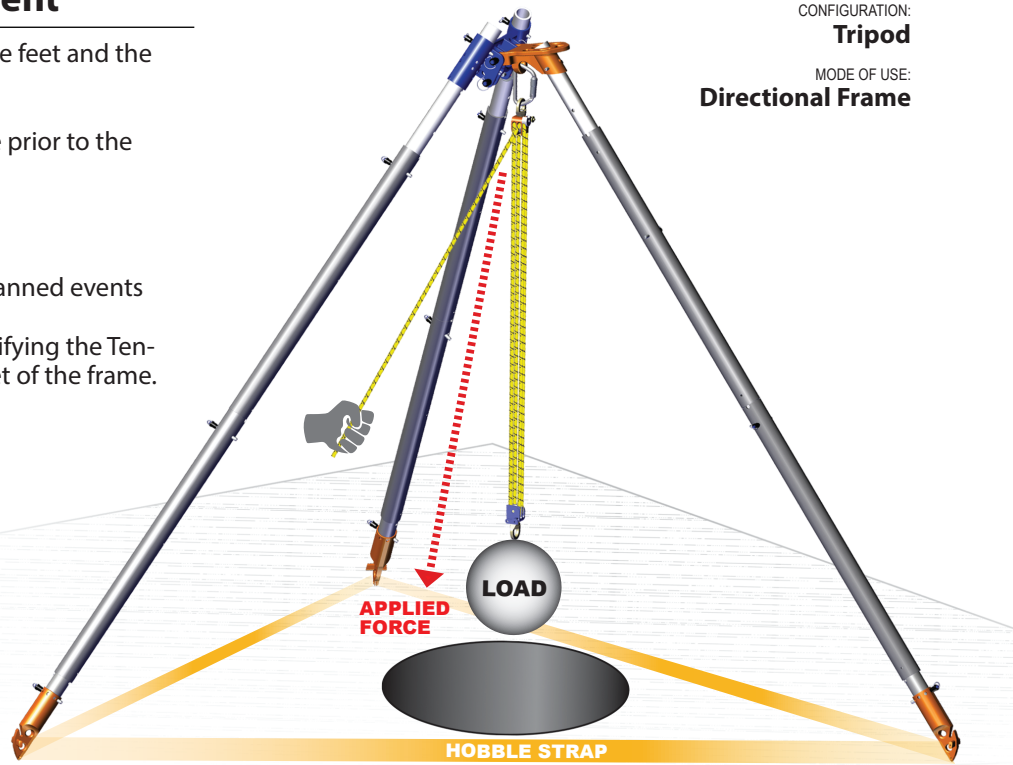
- The unloaded state (standing the frame prior to the application of the load)
- The planned movements of the load
- Foreseeable misuse and potential unplanned events

The following diagrams are a guide to identifying the Tendency of Movement of the head and the feet of the frame.

CONFIGURATION:  
**Tripod**  
MODE OF USE:  
**Directional Frame**

**Fig. 3a**

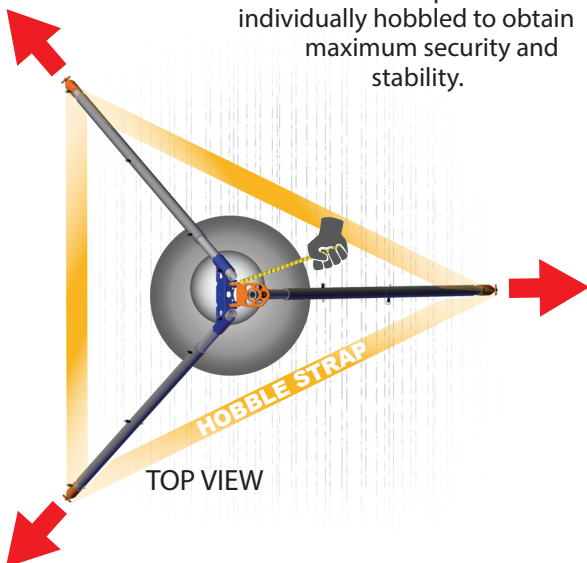
The Equal Leg Tripod shown supporting a CSR2 Pulley System. The applied force in this example is the resultant of the pulley system which is between the load and the hauling line (closer toward the load). This mode of use is as a Directional Frame.



**Fig. 3b**

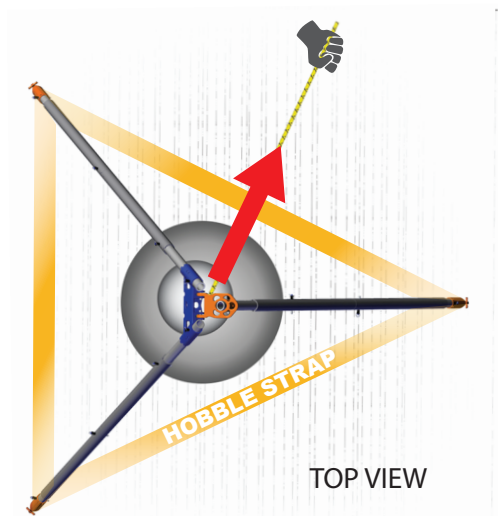
When force is applied on the Equal Leg Tripod, the feet will have a tendency of movement outward, as indicated by the red arrows.

This movement is typically prevented by the use of hobbles between the feet. CMC recommends that each pair of feet be individually hobbled to obtain maximum security and stability.

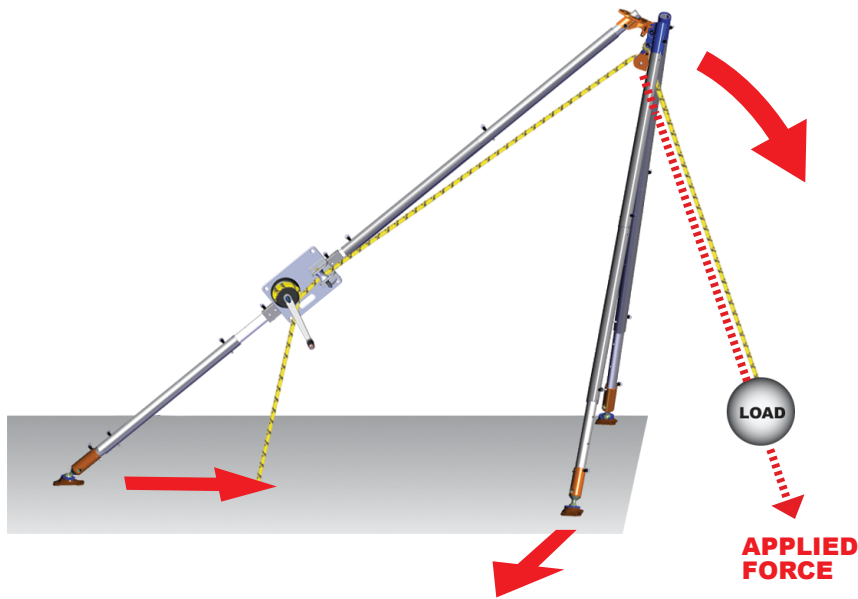


**Fig. 3c**

Care must be taken to ensure the haul line is kept close to the load line. The frame will have a tendency of movement in the direction of the haul if the haul line is extended out to the point where the applied force (pulley system resultant) approaches the hobble.



CONFIGURATION:  
**Easel-Leg Tripod  
 (w/leg-mounted winch)**  
 MODE OF USE:  
**Anchor Frame**



**NOTE: GUY LINES HAVE BEEN OMITTED FROM THIS DIAGRAM FOR CLARITY.** Proper securing of this configuration is absolutely critical to its safe operation.

**Fig. 3d**

When the load is applied, the force acting on the **Anchor Frame** will have a tendency to rotate the Vortex forward toward the load as shown by the arrows.

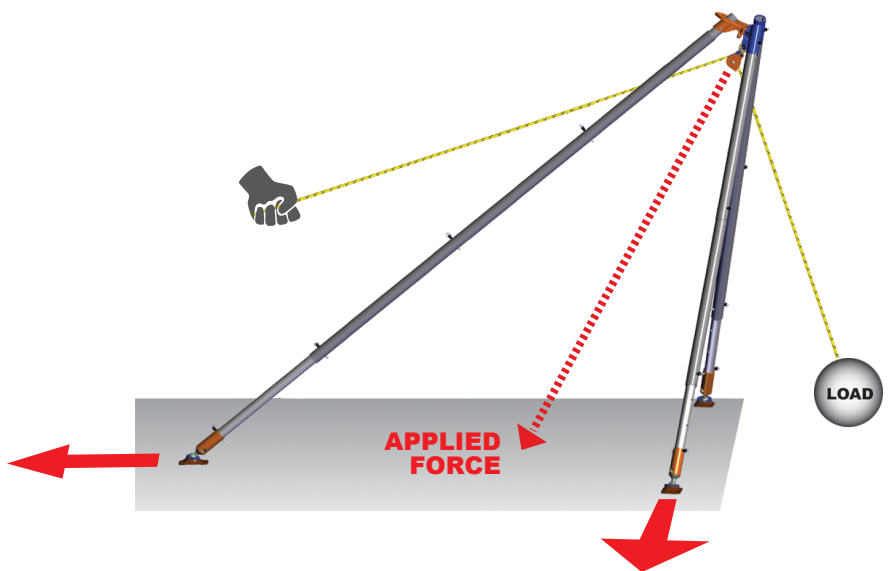
The front legs of the Easel-Leg Tripod will have a tendency to spread apart and backward, while the rear leg will have a tendency to move forward.

The rear leg of an Easel-Leg Tripod must be appropriately secured to control all tensile, compressive and shear (sliding) forces.

CONFIGURATION:  
**Easel-Leg Tripod  
 (w/directional pulley)**  
 MODE OF USE:  
**Directional Frame**

**Fig. 3e**

When the load is applied, the force acting on the **Directional Frame** will cause a rearward tendency of movement. The front legs of the Easel-Leg Tripod will have a tendency to spread apart, while the rear leg will have a tendency to move backwards.

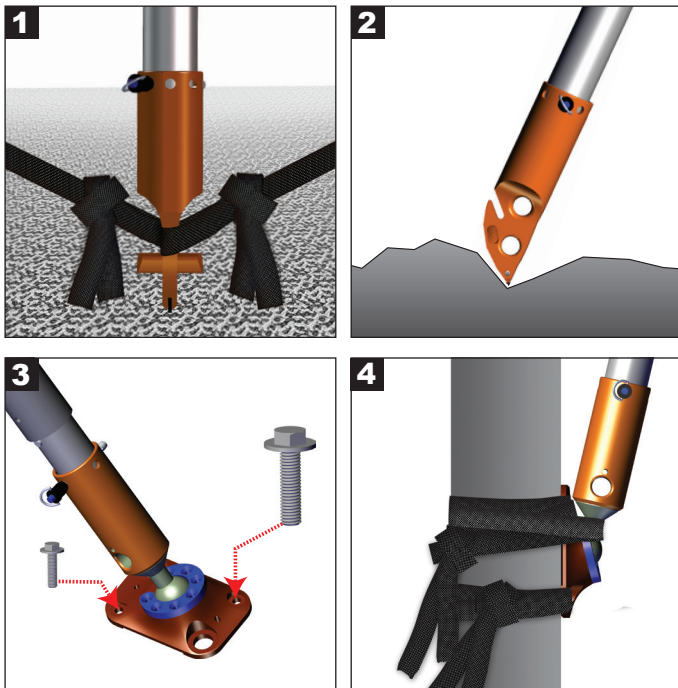


## Step 4a: Securing the Feet

Regardless of configuration, the feet of the Vortex must be secured to control all forms of movement. The securing methods and rigging must resist all tensile, compressive and shear (sliding) forces transferred to the feet via the legs and frame.

The feet must be placed on and/or secured to a surface that will resist the forces applied to the Vortex frame, such as solid ground or substantial structural members. The feet can be secured in numerous ways, including but not limited to:

1. Connect the legs together using independent hobbles between each pair of feet.
2. Wedged or engaged into a natural or artificial niche.
3. Bolted to solid surfaces or structure.
4. Lashed to objects.



## Step 4b: Securing the Head

The head of the frame must be secured to resist the tendency of movement. The head is typically secured through a combination of legs in compression, legs in tension and guys in tension.

In some cases, the force acting on a guy may exceed the force applied by the load. Care must be taken to ensure that all components used are able to resist the forces applied with the required factor of safety or safety margin. The number and position of guys is dependent on the Vortex configuration and its intended function.

### For Steps 4a & 4b:

Adjustable Hobble Straps and Tether Cord are supplied with the CMC Arizona Vortex Kit. CMC recommends the following criteria for choosing additional guying material:

1. Lightweight
2. High Strength
3. Small Diameter
4. Very Low Elongation

## Step 5: Guy Angles

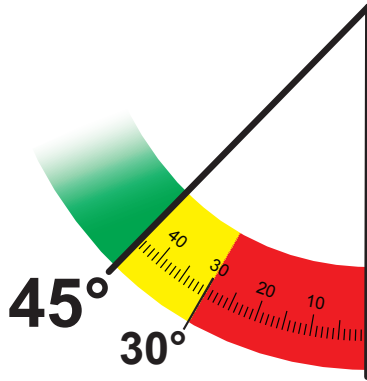
The Guy Angle and the Applied Force Angle are the key factors used to determine the forces acting on the guys and the Vortex frame. These forces can be precisely calculated; however, to allow the user to quickly ensure that the forces are within an acceptable range, the following rules-of-thumb should be used.

Whenever possible, the Guy Angle should be kept above 45°. In some situations this may not be possible. However, under no circumstance should the Guy Angle be less than 30°. If these rules are met, the magnitude of the force on the guy will not exceed that of the applied force.

In some configurations there may be multiple guys supporting the Vortex. It is essential that the user properly identify which guyline will resist the Tendency of Movement of the Vortex. It is this guyline (or Guy Plane if multiple guylines are used) that must meet the Guy Angle Rules described in this section.

The positioning of components described in this section may be relative to the angle of a Guy Plane, rather than to a single guy, and to a Frame Plane, than to a single leg of the frame (see fig. 5c & 5d).

1. Guy Angle should not be less than 30°, ideally not less than 45°.



2. Guy Angle not less than the Applied Force Angle



**Fig. 5a**

### Guy Angles on Anchor Frame

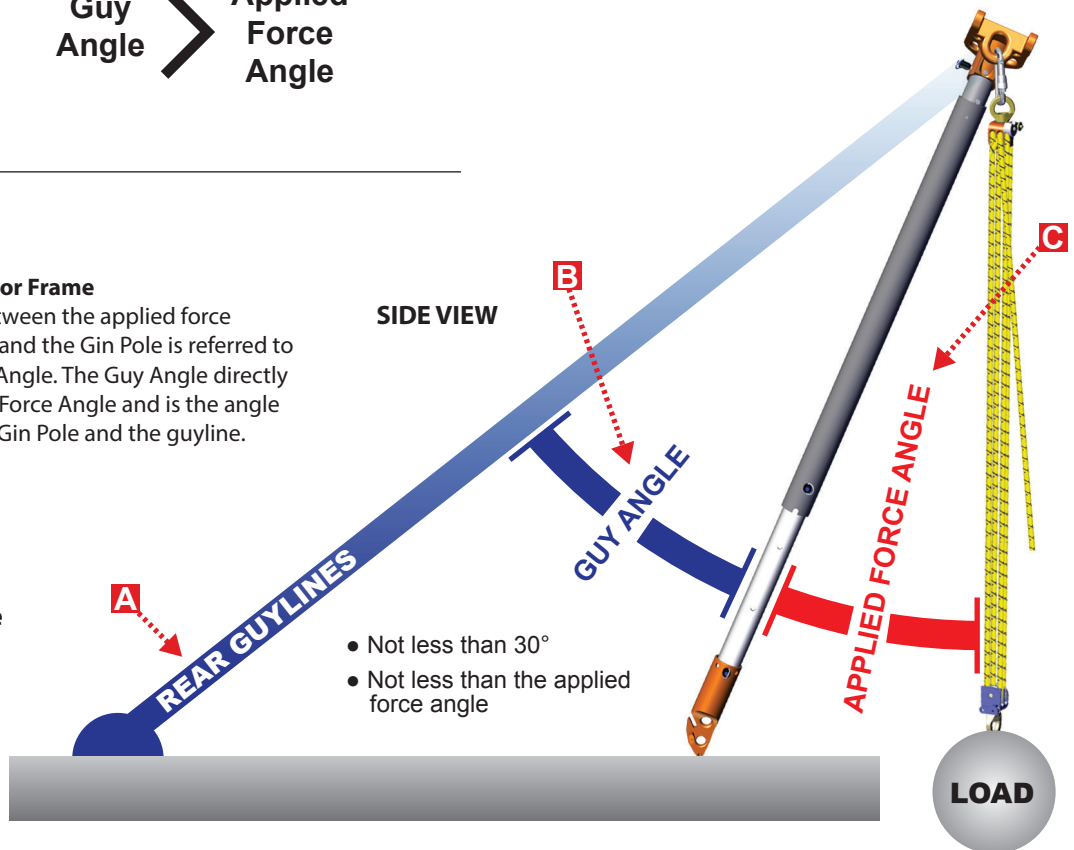
The angle formed between the applied force (CSR2 Pulley System) and the Gin Pole is referred to as the Applied Force Angle. The Guy Angle directly opposes the Applied Force Angle and is the angle formed between the Gin Pole and the guyline.

CONFIGURATION:

**Gin Pole**

MODE OF USE:

**Anchor Frame**



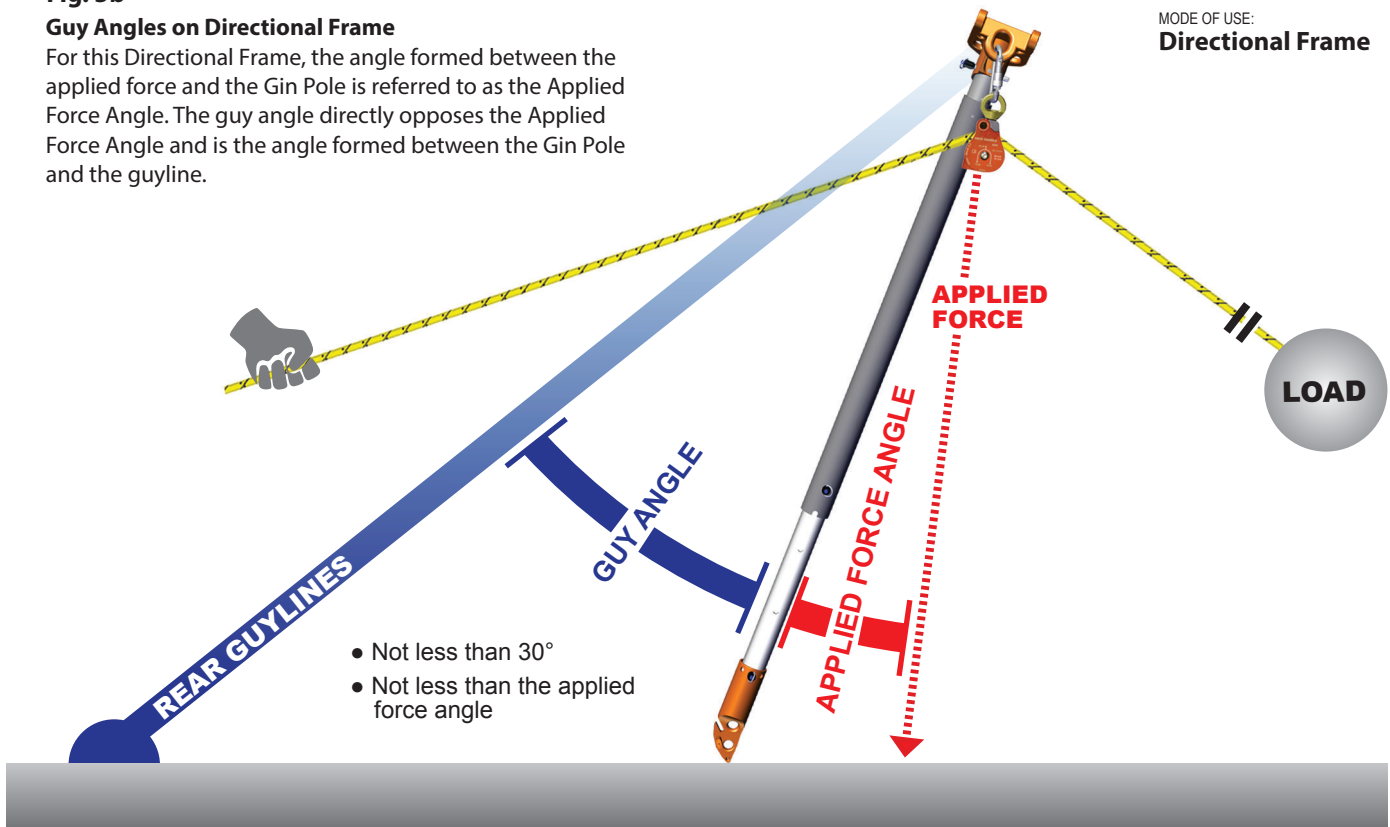
**Fig. 5b**

**Guy Angles on Directional Frame**

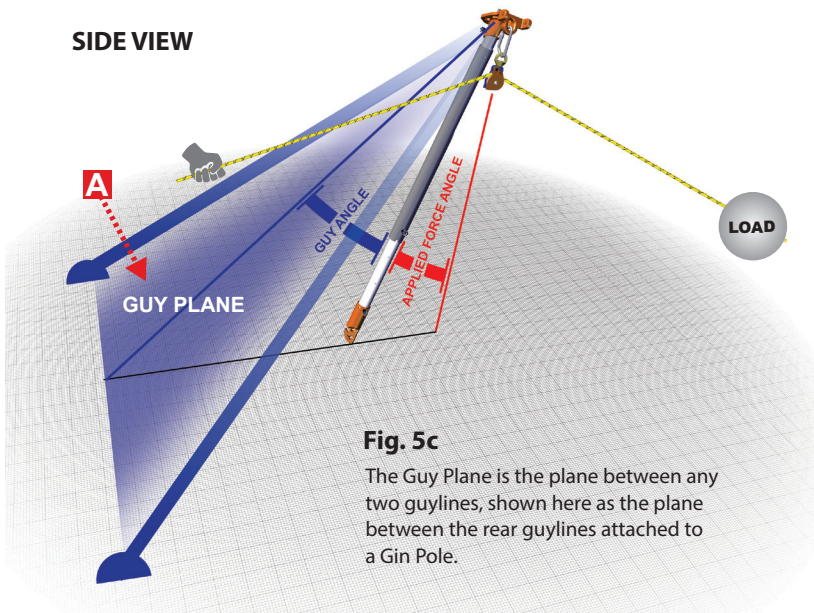
For this Directional Frame, the angle formed between the applied force and the Gin Pole is referred to as the Applied Force Angle. The guy angle directly opposes the Applied Force Angle and is the angle formed between the Gin Pole and the guyline.

CONFIGURATION:  
**Gin Pole**

MODE OF USE:  
**Directional Frame**



**SIDE VIEW**

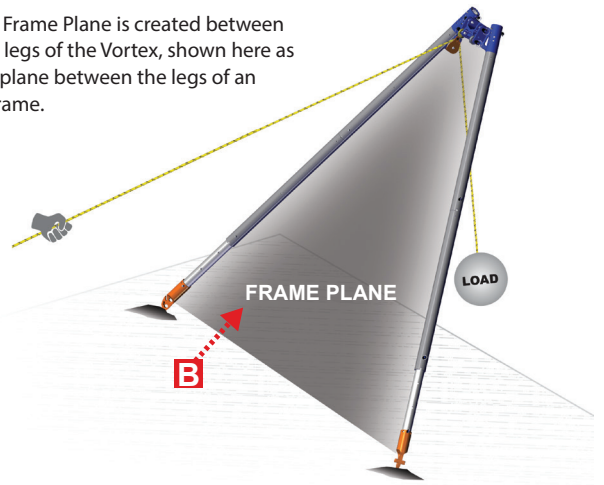


**Fig. 5c**

The Guy Plane is the plane between any two guylines, shown here as the plane between the rear guylines attached to a Gin Pole.

**Fig. 5d**

The Frame Plane is created between two legs of the Vortex, shown here as the plane between the legs of an A-Frame.



## Step 6: Strength & Stability

The strength and security of the Vortex should be tested prior to use. This may be achieved by applying a test load to the system and checking that all components are correctly performing their function.

The Vortex has been extensively tested for strength in a controlled environment. The results of the testing prove that the Vortex can be safely used to support personnel in a wide variety of configurations.

Extreme caution must be exercised by the user if configurations other than those described within this manual are used. Additional Vortex-specific training from a qualified instructor is highly recommended.

Ways to maximize the strength and stability of the Vortex are:

- Minimize the height.
- Minimize the length of legs.
- Connect the Outer Leg coupler into the Gin Pole head so the Inner Leg is toward the foot.
- Connect to the center Gin Pole (orange) yoke when using a Tripod configuration.
- Connect to the vertical center connection point of the A-Frame (blue) Head when using an A-Frame.
- Connect opposing guys to the same point on the head to reduce the twisting tendency on the head.
- Use appropriate material and methods for hobbles, lashings and guys (as described in the “Securing the Feet” and “Securing the Head” sections).
- Ensure acceptable guy and Applied Force Angles.
- Minimize transverse stresses on the legs by ensuring leg forces are predominantly axial. Ensure mid-span leg connections are loaded axially. Do not allow objects or structures to contact the legs mid-span.
- Select anchors of appropriate strength.
- Carefully plan and select the most appropriate rigging equipment and techniques.

### SUPPORT STRUCTURE / SURFACE REQUIREMENTS

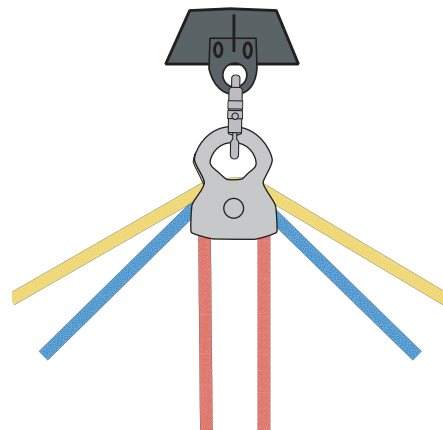
The strength requirement of the support structure / surface varies depending on the Mode of Use and application.

### ANCHOR FRAME:

The structure / surface selected must sustain a static load equal to that specified for the application, in the direction permitted by the system when in use.

### DIRECTIONAL FRAME:

The load factor of the directional pulley must be considered when determining the support strength requirement. The structure / surface selected must sustain a static load equal to that specified for the application multiplied by the load factor, in the direction permitted by the system when in use.



Interior Angle	Resultant Force
120° (Yellow Line)	= 1 times the load
90° (Blue Line)	= 1.41 times the load
0° (Red Line)	= 2 times the load

## Configurations

On the following pages is a simple guide to the most commonly used Vortex configurations. Each of the following standard configurations has specific attributes, rigging requirements and usage guidelines that should be followed. Other, more complex configurations require advanced rigging skills and expert evaluation prior to being placed in service.

CONFIGURATIONS

# EQUAL-LEG TRIPOD

The Equal-Leg Tripod shown is a **Directional Frame**, as the frame supports a pulley system and the haul line is not terminated onto the frame. The use of independent hobbles alone is normally considered acceptable to secure the feet in this configuration.

In this case, the hobbles form a triangle between the feet. Ideally the load should be suspended in the center of the triangle. As the load is moved away from the center of the triangle the Tripod will have a tendency to topple.

Care must be taken to ensure that the load is kept in the center of the triangle. Additionally, keep the haul line close to the load line to prevent tendency of movement on the head of the frame.

NOTE: GUY LINES OMITTED AND HOBBLE STRAPS FOR CLARITY.

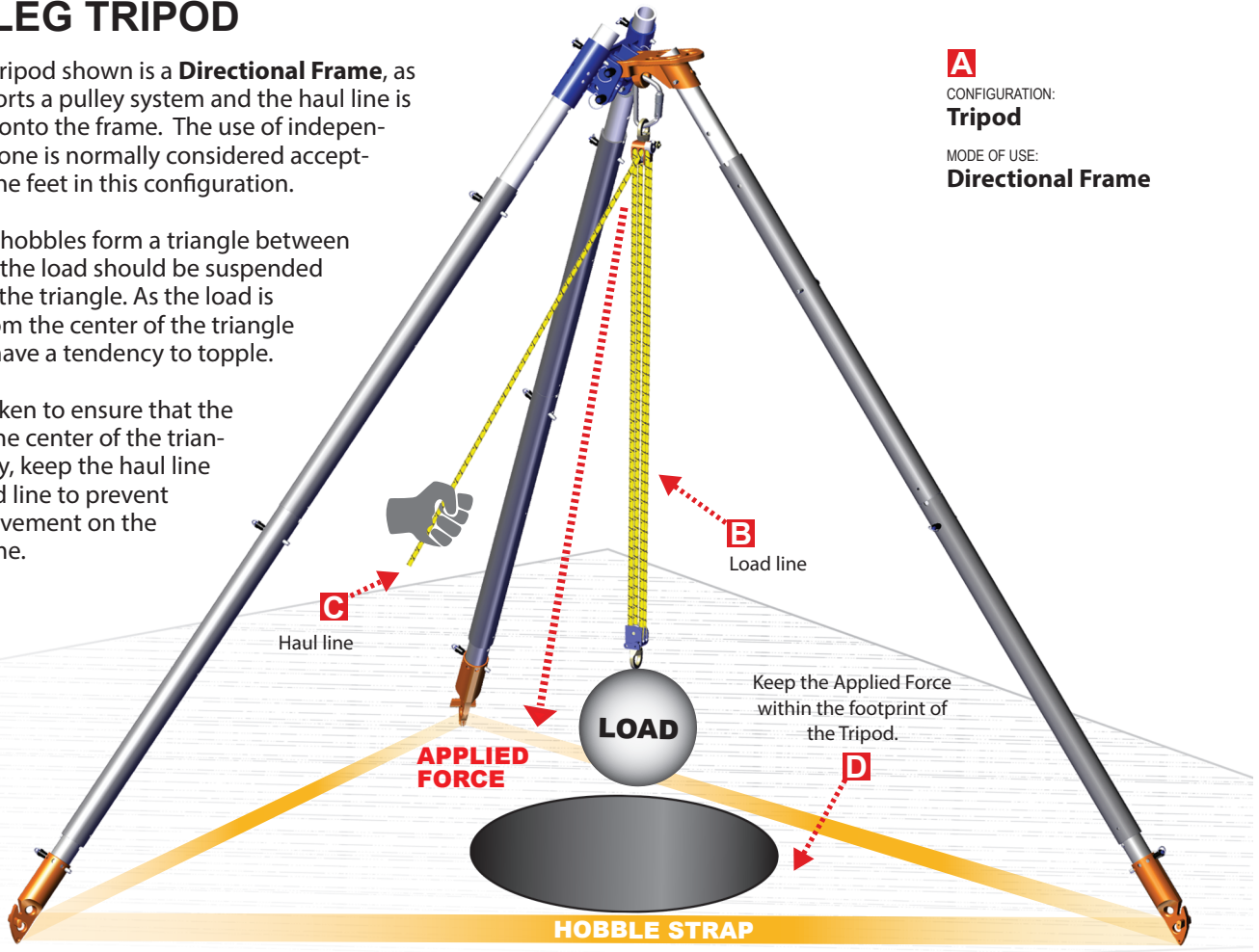
**A**

CONFIGURATION:

**Tripod**

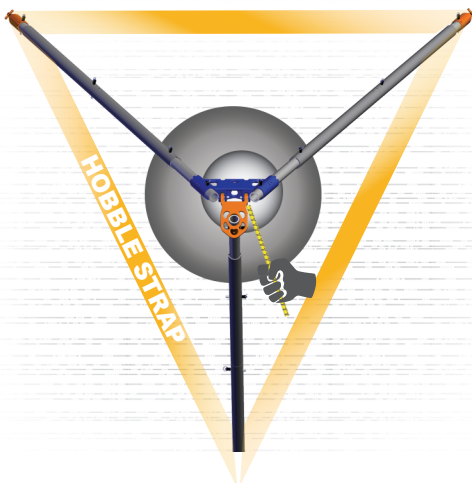
MODE OF USE:

**Directional Frame**

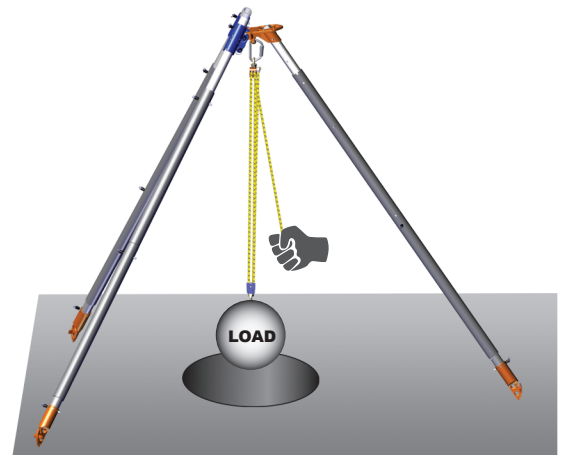


## — VIEWS —

TOP VIEW



SIDE VIEW



CONFIGURATIONS

# EASEL-LEG TRIPOD (with Leg-Mounted Winch)

The Easel-Leg Tripod shown is an **Anchor Frame** as the rope that supports the load is anchored to the frame via a leg-mounted winch. The use of hobbles alone is normally considered acceptable to secure the feet in this configuration. However, the action of cranking the winch may cause unwanted movement of the Easel-Leg.

As with the Equal-Leg Tripod, the hobbles form a triangle between the feet. Ideally the load should be suspended in the center of the triangle. As the load is moved toward the outside of the triangle, the Tripod will tend to topple.

Care must be taken to ensure the load is kept well within the triangle.

**A**  
CONFIGURATION:  
**Easel-Leg Tripod (with  
leg-mounted winch)**  
MODE OF USE:  
**Anchor Frame**

Keep the Applied Force  
within the footprint of  
Easel-Leg Frame.

**B**

**APPLIED  
FORCE**

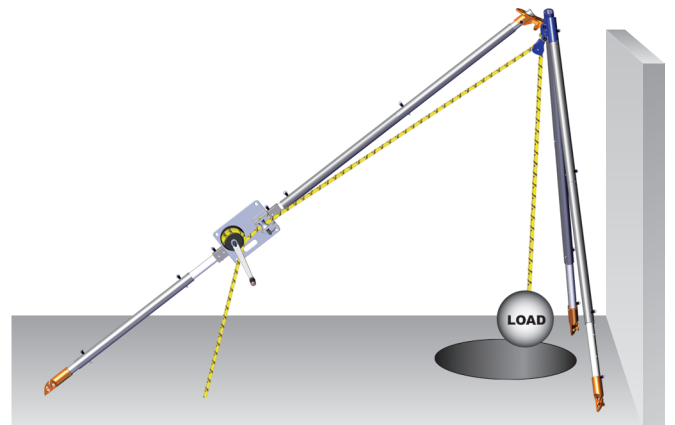
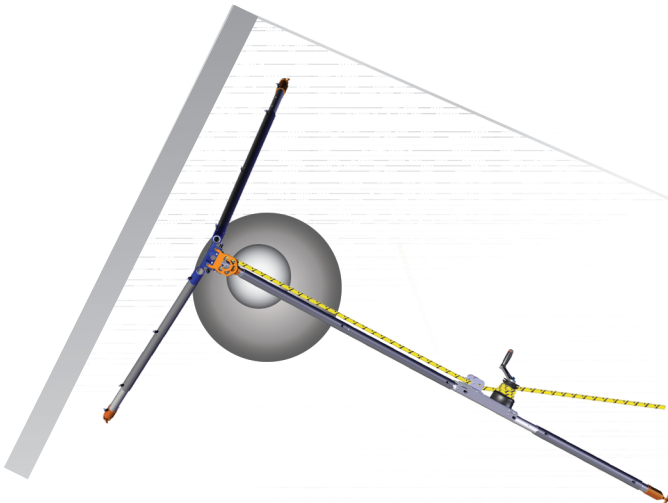
**LOAD**

**HOBBLE STRAP**

VIEWS

TOP VIEW

SIDE VIEW





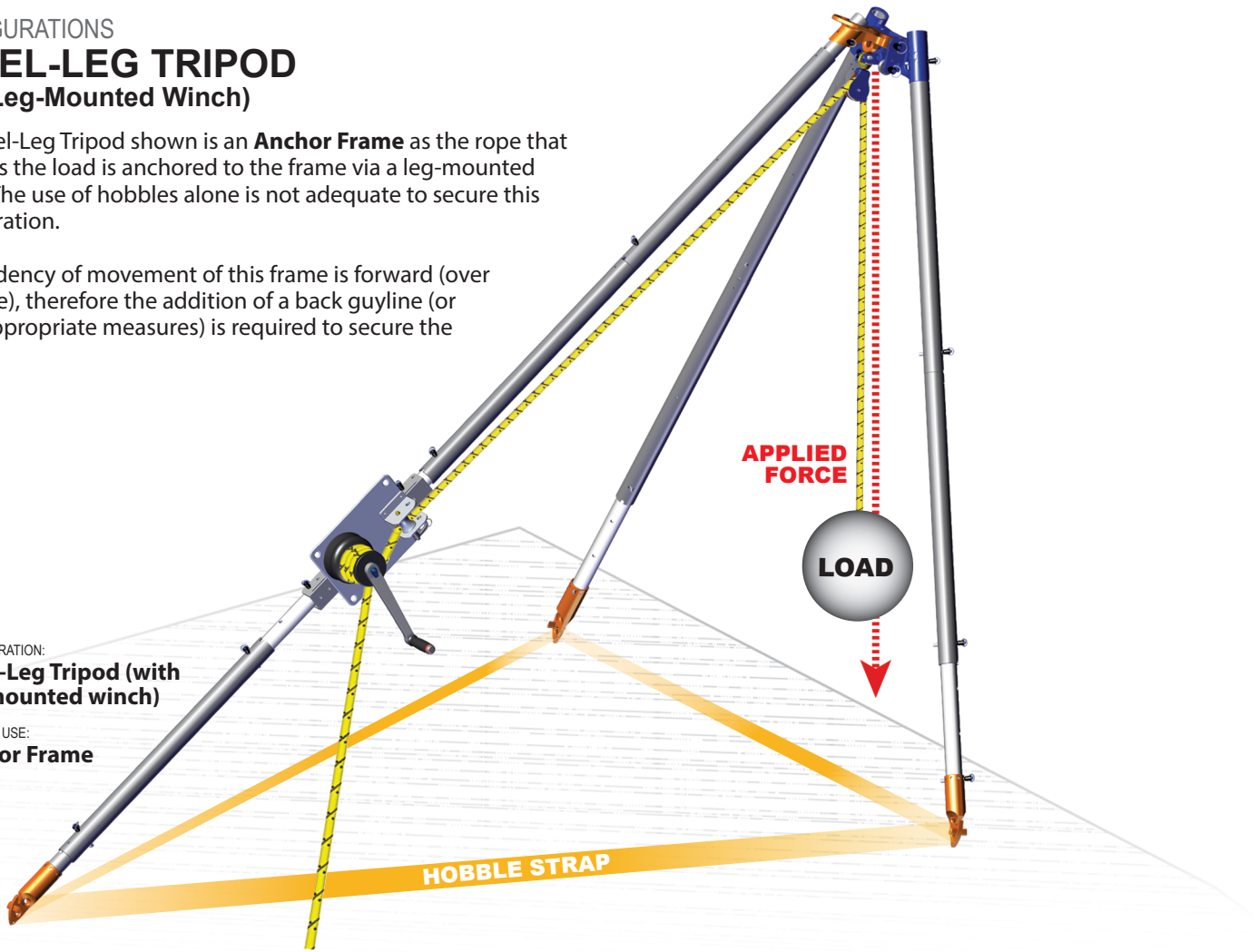
CONFIGURATIONS

# EASEL-LEG TRIPOD (with Leg-Mounted Winch)

The Easel-Leg Tripod shown is an **Anchor Frame** as the rope that supports the load is anchored to the frame via a leg-mounted winch. The use of hobbles alone is not adequate to secure this configuration.

The tendency of movement of this frame is forward (over the edge), therefore the addition of a back guyline (or other appropriate measures) is required to secure the frame.

**A**  
CONFIGURATION:  
**Easel-Leg Tripod (with  
leg-mounted winch)**  
MODE OF USE:  
**Anchor Frame**

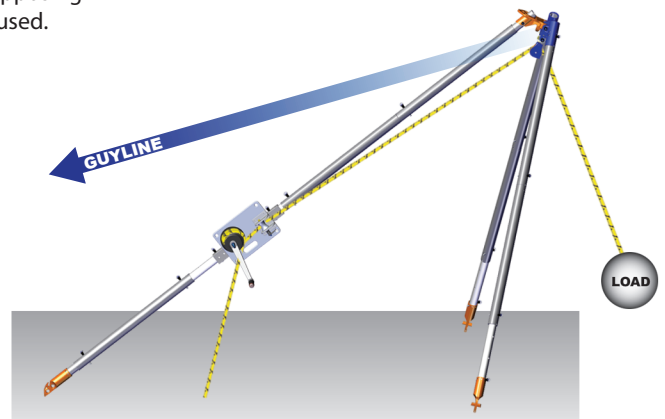
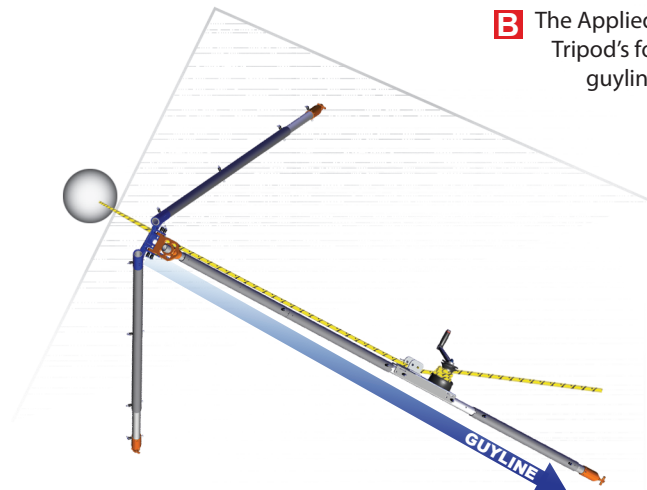


TOP VIEW

VIEWS

SIDE VIEW

**B** The Applied Force is outside of the Tripod's footprint. An opposing guyline(s) must be used.



CONFIGURATIONS

# EASEL-LEG TRIPOD (with Directional Pulley)

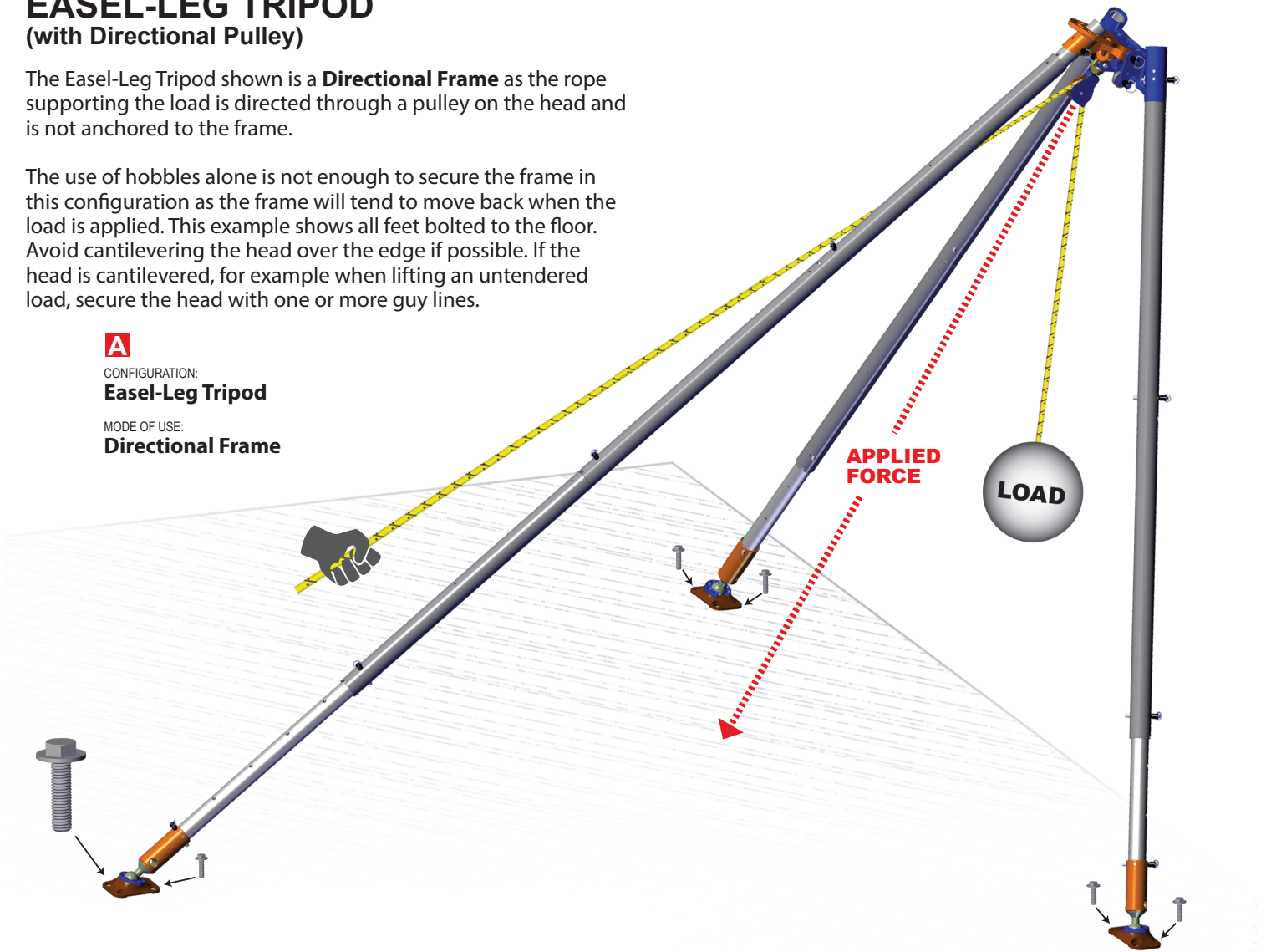
The Easel-Leg Tripod shown is a **Directional Frame** as the rope supporting the load is directed through a pulley on the head and is not anchored to the frame.

The use of hobbles alone is not enough to secure the frame in this configuration as the frame will tend to move back when the load is applied. This example shows all feet bolted to the floor. Avoid cantilevering the head over the edge if possible. If the head is cantilevered, for example when lifting an untendered load, secure the head with one or more guy lines.

**A**

CONFIGURATION:  
**Easel-Leg Tripod**

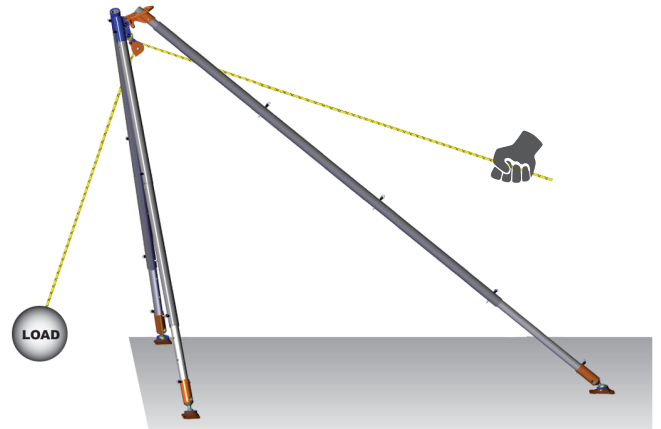
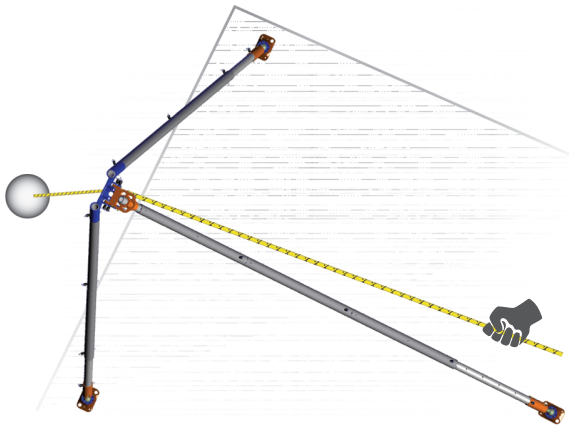
MODE OF USE:  
**Directional Frame**



VIEWS

TOP VIEW

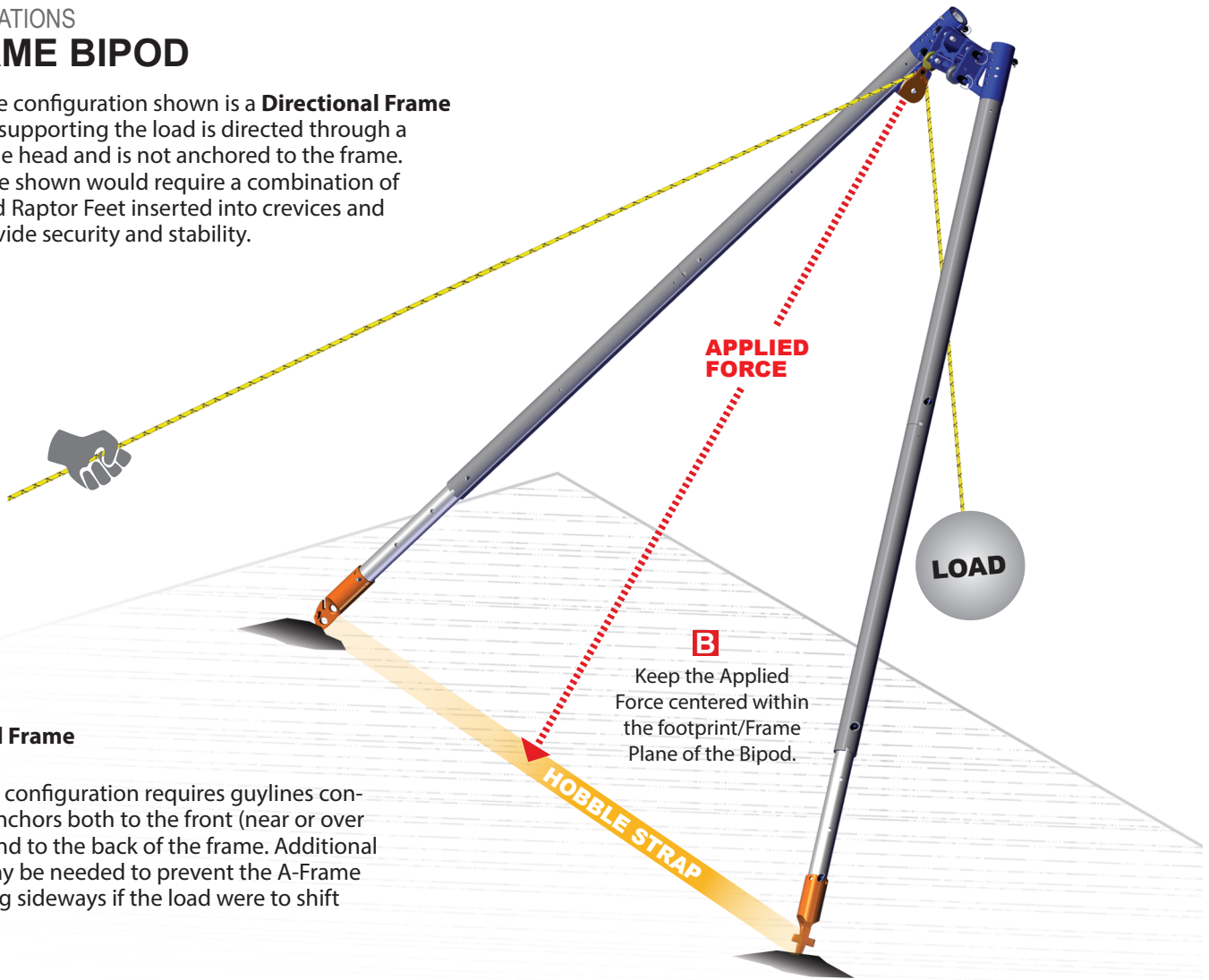
SIDE VIEW



CONFIGURATIONS

# A-FRAME BIPOD

The A-Frame configuration shown is a **Directional Frame** as the rope supporting the load is directed through a pulley on the head and is not anchored to the frame. The example shown would require a combination of hobbles and Raptor Feet inserted into crevices and guys to provide security and stability.

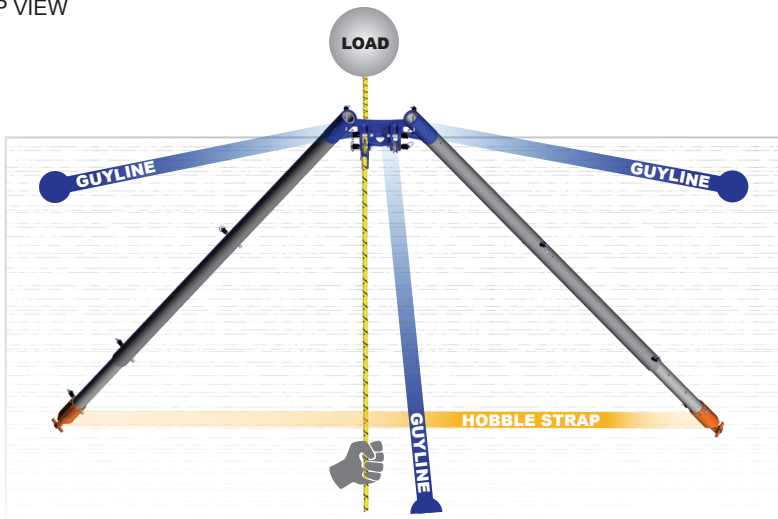


**A**  
CONFIGURATION:  
**A-Frame**  
MODE OF USE:  
**Directional Frame**

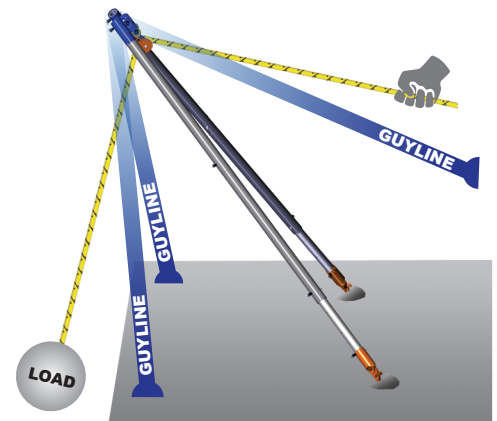
An A-Frame configuration requires guylines connected to anchors both to the front (near or over the edge) and to the back of the frame. Additional guylines may be needed to prevent the A-Frame from moving sideways if the load were to shift laterally.

## VIEWS

TOP VIEW



SIDE VIEW

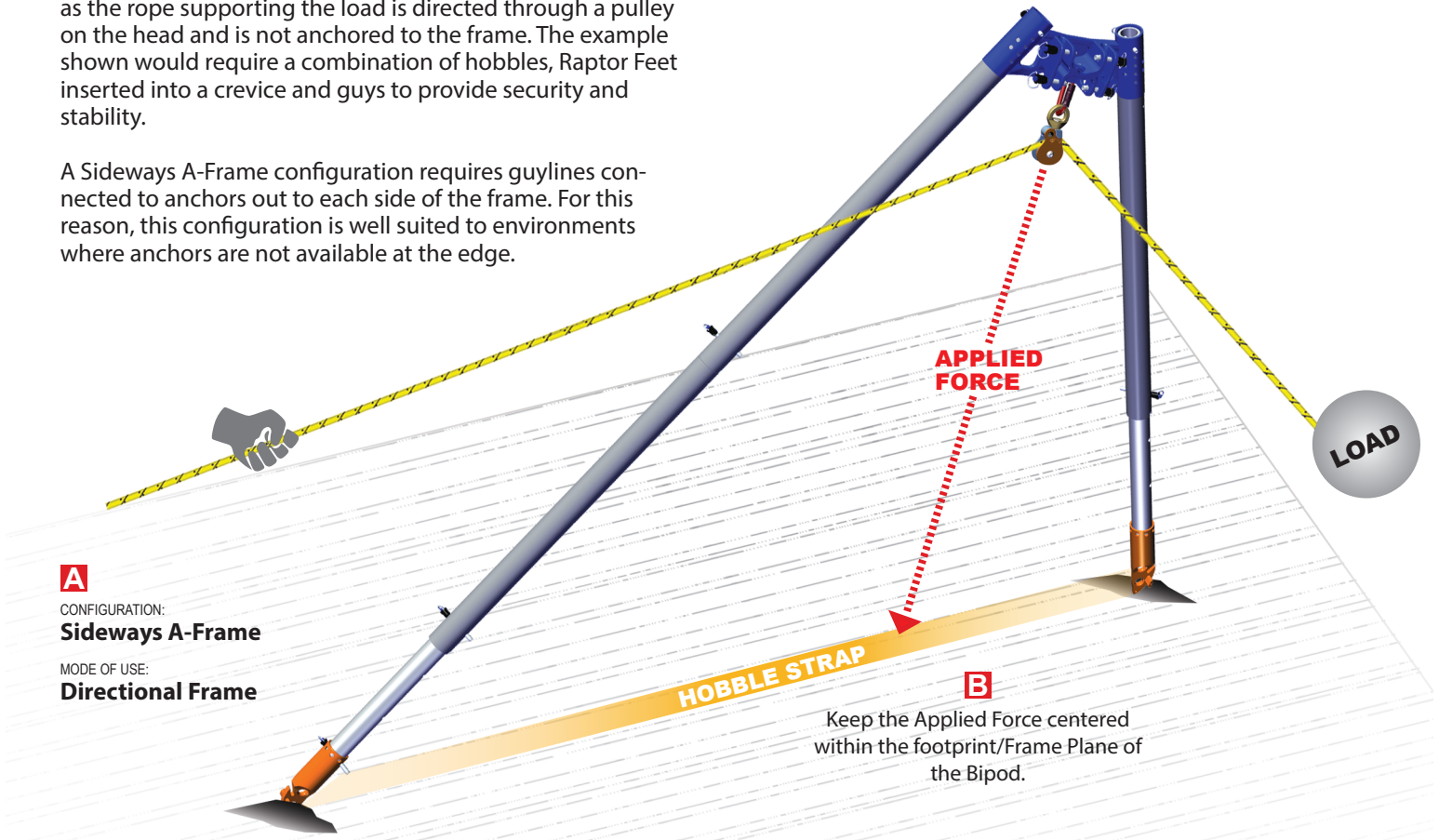


CONFIGURATIONS

# SIDEWAYS A-FRAME

The Sideways A-Frame Bipod shown is a **Directional Frame** as the rope supporting the load is directed through a pulley on the head and is not anchored to the frame. The example shown would require a combination of hobbles, Raptor Feet inserted into a crevice and guys to provide security and stability.

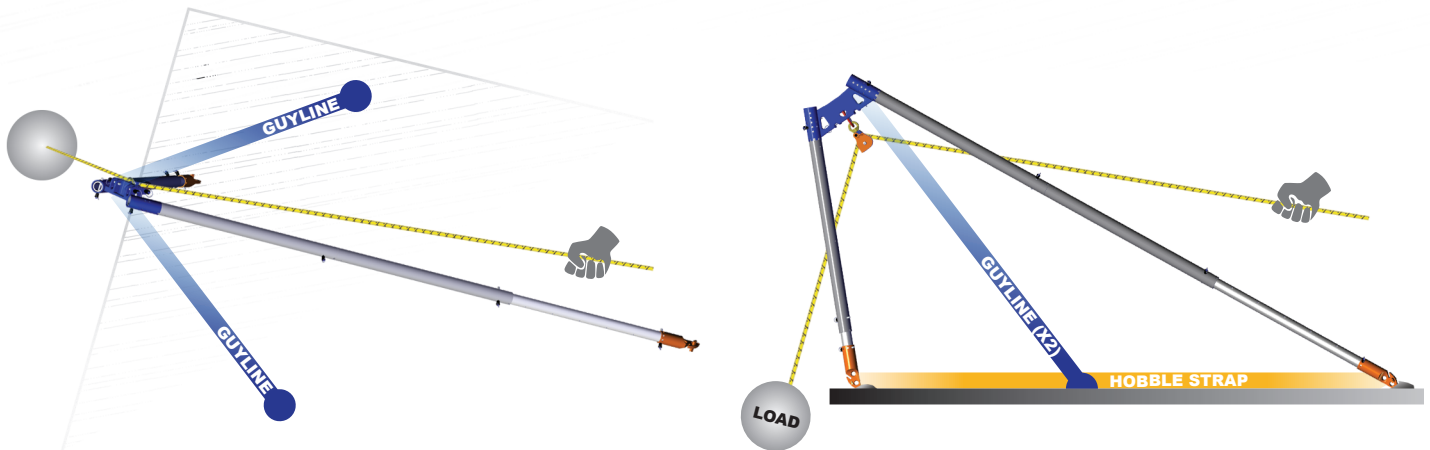
A Sideways A-Frame configuration requires guylines connected to anchors out to each side of the frame. For this reason, this configuration is well suited to environments where anchors are not available at the edge.



## VIEWS

TOP VIEW

SIDE VIEW



CONFIGURATIONS

# GIN POLE MONOPOD

The Gin Pole configuration shown is a **Directional Frame** as the rope supporting the load is directed through a pulley on the head and is not anchored to the frame. The example shown would require a combination of hobbles, Raptor feet inserted into a crevice and guys to provide security and stability.

A Gin Pole configuration requires a minimum of three (3) guys, ideally separated by 120°. This may prove to be difficult to achieve in some environments as suitable anchors may not be available. Additional guys may be necessary in these situations.

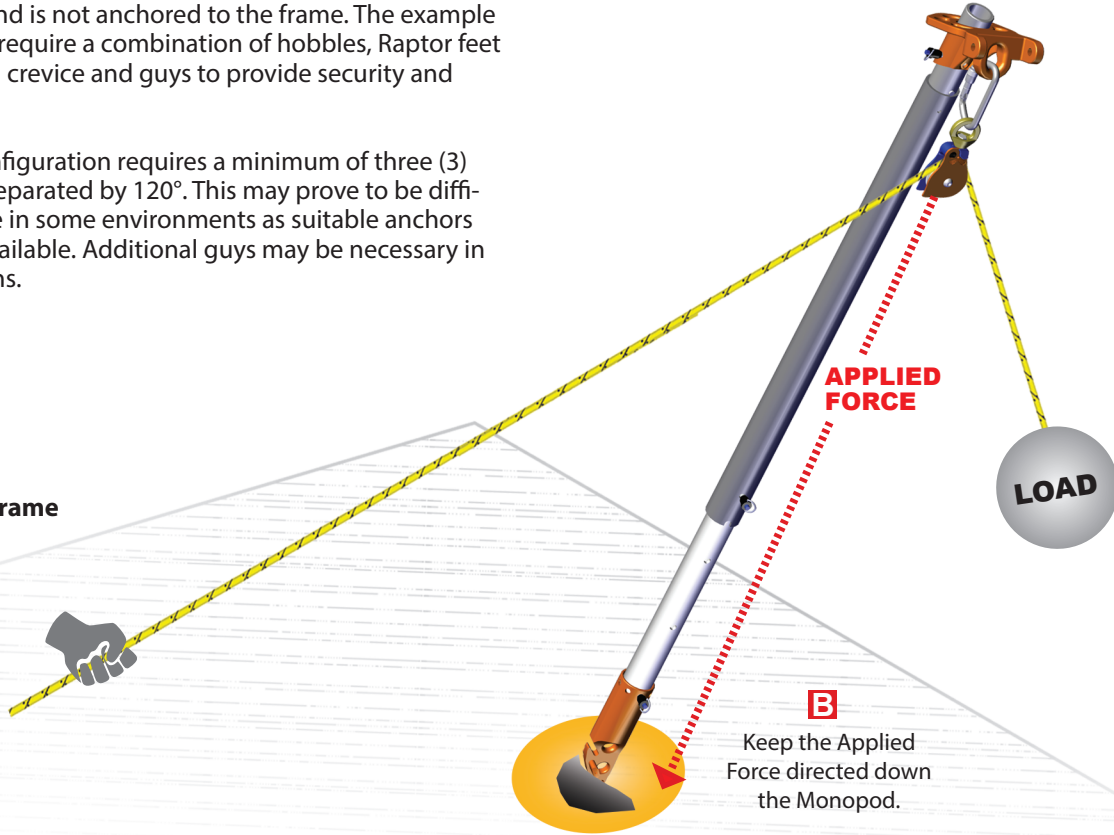
**A**

CONFIGURATION:

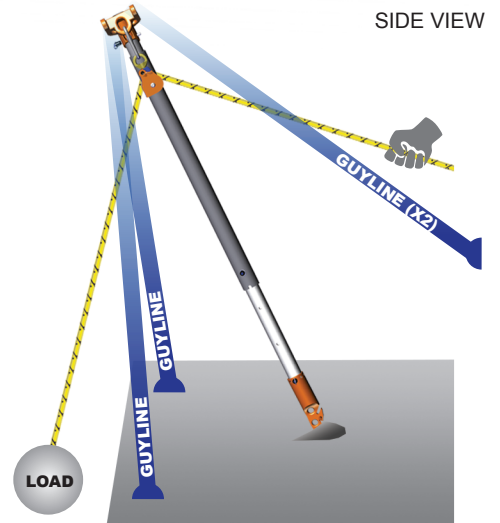
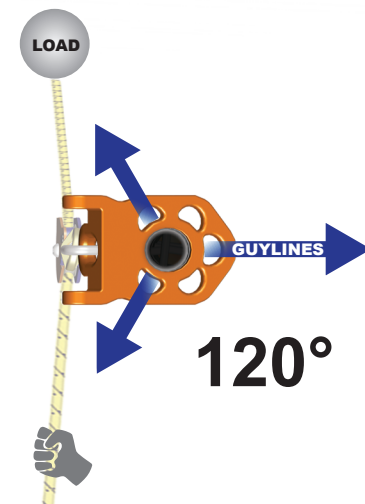
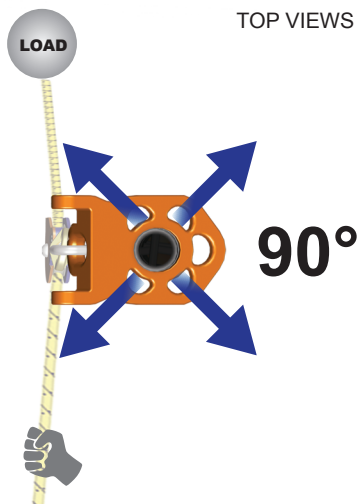
**Gin Pole**

MODE OF USE:

**Directional Frame**



## VIEWS



## USAGE INSPECTION

### Before and After Each Use

---

Perform a visual, tactile and functional inspection of all parts.

Check components for:

- Sharp edges
- Nicks, gouges, dings, wear, scratches or indentations deeper than 1mm
- Permanent deformation
- Misalignment of joining parts
- Legs that do not easily fit together and adjust smoothly
- Bent, twisted, distorted, stretched, elongated, cracked, or broken components
- Unauthorized replacement components
- Legibility of the product markings
- Evidence of:
  - a. Being dropped
  - b. Excessive loading
  - c. Corrosion
  - d. Exposure to heat, including weld spatter, arc strikes, or discoloration of the surface
  - e. Unauthorized modification or repair

## VORTEX PINS

- Operation of locking pin not smooth and positive
- Locking balls not fully seated

## HEADSET PULLEY

- Misalignment or wobble in the bearing
- Excessive sheave wear
- Grooves or other deformation in the tread of the sheave
- Sharp edges on the sheave
- Rotation of the bearing not smooth and effortless

## PERIODIC INSPECTION

### Detailed Periodic Inspection

---

Remove the Vortex from service and discontinue use if:

- Any component fails inspection
- It has been used to arrest a fall or has been significantly loaded
- If there is any doubt about its condition.

Do not return to service until the unit in question has been inspected and approved for use in writing by a competent person that is authorized to do so. Contact CMC if you have any doubts or concerns.

Inspections should be performed by a competent person whose training meets the applicable standards and/or laws for the inspection of life safety equipment. An inspection log including the date, inspectors name, and result of the inspection should be kept as a permanent record. It is best to issue new equipment to each user so they know its entire history.


Repairs or modifications to the equipment are only allowed by CMC or those authorized in writing by the manufacturer. Other work or modifications may void the warranty, and releases CMC from all liability and responsibility.

CMC offers training in the setup, use, and application of the Arizona Vortex Kit. Please visit [cmcpro.com](http://cmcpro.com) for more information on class schedules and locations.





**CMC Rescue, Inc.**  
**6740 Cortona Drive**  
**Goleta, CA 93117, USA**  
**805-562-9120 / 800-235-5741**  
**cmcpro.com**

ISO 9001 Certified  
©2020 CMC Rescue, Inc. All rights reserved  
CMC and  are registered marks of CMC Rescue Inc.  
Control No. 910001\_Rev00